

Actinomycin. Chemistry and Mechanism of Action

ULRICH HOLLSTEIN

Department of Chemistry, The University of New Mexico, Albuquerque, New Mexico 87131

Received June 27, 1973 (Revised Manuscript Received November 12, 1973)

Contents

I. Introduction	625
A. Historical Development	625
B. Purpose and Scope	625
C. Nomenclature, Symbols, and Abbreviations	626
II. Synthesis	627
A. Biosynthesis	627
B. Synthesis of Actinomycins	628
C. Proof of Two Pentapeptide Lactone Rings	634
D. Synthesis of Actinomycin Analogs	636
III. X-Ray Studies	639
IV. Behavior of Actinomycin in Solution	639
A. Dimerization	629
B. CD/ORD Studies	639
C. Nmr Studies	640
V. Complexes with Constituents of Nucleic Acids	643
VI. Binding of Actinomycin to DNA	645
VII. Models for the Actinomycin-DNA Complex	646
VIII. Biological Activity	650
IX. Addendum	650
X. References	650

I. Introduction

A. Historical Development

The actinomycins are orange to red antibiotic metabolites from various species of *Streptomyces*. Although these compounds are highly toxic, they have found usage in nontoxic dosages because of their antineoplastic effect. Actinomycins D(C₁) and C₃ are highly effective chemotherapeutics in the treatment of Wilms' tumor, trophoblastic tumors, and rhabdomyosarcoma.¹ Current therapeutic efforts are largely directed at utilization of the drug in combination with other active agents against these tumor types. Because of its binding to DNA and subsequent inhibition of RNA synthesis, actinomycin has become an important tool in molecular and cell biology. The exciting potentialities of actinomycin D have stimulated a great deal of research into its chemical and physical nature. One of the primary objectives of such studies has been the interpretation of the biological activity in terms of a plausible molecular structural model.

The group name actinomycin was coined by Waksman, who discovered these antibiotics in cultures of *Actinomyces antibioticus* in 1940.² Only 9 years later publications revealed a first glimpse into the structure of actinomycins. Early work by Todd's and Johnson's school^{3,4} was soon followed by a major investigative effort by Brockmann's school, starting in 1949⁵ and continuing to the present.

In 1960 the constitution of the actinomycins had been

well established, and a first total synthesis of an actinomycin had been achieved.⁶

The actinomycins had at an early stage of the investigation been recognized as chromopeptides; that is, the molecule contains a chromophore moiety, absorbing in the visible, linked to a peptide part. Thus, two distinct structural problems had to be solved: (i) the structure of the chromophore with the point of attachment of the peptide and (ii) the amino acid sequence in the peptide. After initial difficulties caused by unwanted isomerizations and transformations, the actinomycin chromophore "actinocin" could be isolated and was assigned the structure 3-amino-1,8-dimethyl-2-phenoxazone-4,5-dicarboxylic acid. It is of interest to note that the same 2-amino-3-phenoxazone ring system is found in the ommochrome insect eye pigments⁷ and in several pigmented mold metabolites.⁸ It was then determined that the chromophore carried as amides, at its two carboxyl groups two pentapeptides, whose amino acid sequences were elucidated by various partial hydrolyses.⁹

Actinomycins with the same two pentapeptide residues are called isoactinomycins, while those with two different residues are referred to as anisoactinomycins. The amino acids linked by amide bonds to the 4- and 5-carboxyls are always L-threonine whose hydroxyl is always lactonized with the carboxyl of the fifth amino acid. The second amino acid can be D-valine or D-*allo*-isoleucine, the third can be L-proline, L- γ -hydroxyproline, L- γ -ketoproline, pipercolic acid, or sarcosine, the fourth is always sarcosine, and the fifth can be L-N-methylvaline or L-N-methylisoleucine. It is remarkable that the peptide groups contain free NH groups only in the two threonine residues since all other amino groups are methylated or contained in the ring of an imino acid. Also, it is of interest that the second amino acid (valine or *allo*-isoleucine) has the "unnatural" D configuration.

The limits within which a peptide group is variable are relatively narrow. Yet, the existence of numerous actinomycins is possible because of the unusual structure. A cell which during the biosynthesis is limited to *n* patterns of one chain can theoretically synthesize *n*² actinomycins. As an example, the structure of the presently most studied actinomycin D ("Dactinomycin," "Actinomycin C₁") is shown (1).

B. Purpose and Scope

Several reviews cover the literature on actinomycins through 1961.¹⁰⁻¹⁶ The literature from 1961 through May 1973 which is reviewed here contains further synthetic work, investigations into the secondary and tertiary structure of actinomycin, studies on the binding of actinomycin to mono- and polynucleotides, and a considerable

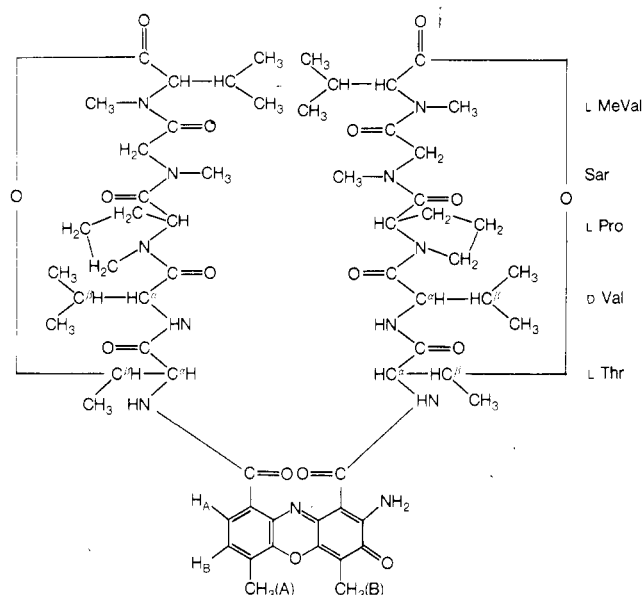

MeVal = *N*-methylvaline; Sar = sarcosine; Pro = proline; Val = valine; Thr = threonine

1

amount of work toward establishment of a model for the mechanism of antibiotic action of actinomycin. The latter aspect has been reviewed several times in recent years.¹⁷⁻²⁴

This review is written because interest in these unusual compounds has continued in the areas of chemistry, molecular biology, and medicine and because no comprehensive survey of the findings of the last decade has been published. Its contents are not extended into the fields of medicine and cell biology.

C. Nomenclature, Symbols, and Abbreviations

During the early years of investigation several different crystalline actinomycin preparations were available to the investigators. These were later recognized as mixtures and could be separated by various partition chromatographic techniques. According to their characteristic chromatographic properties or origins, the mixtures were referred to as C, D, E, F, I, X, and Z and Roman numerals. Components carry designations such as C, C₂, C₃, whereby the increasing subscript refers to increasing *R_f* value. A second index was necessary when new components with intermediate *R_f* values were isolated. For instance, actinomycin X_{2a} travels between X₂ and X₃. When seemingly homogenous fractions could be further separated, a different second index was introduced. Separation of the X₀ fraction led to components X_{0β}, X_{0γ} with increasing *R_f* values.

The following abbreviations are used throughout the rest of this review:

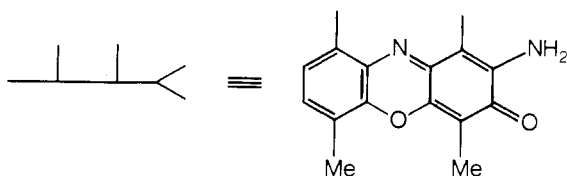

α chain = peptide chain on benzenoid ring

β chain = peptide chain on quinoid ring

Thr = *L*-threonine

Val = *D*-valine

a-lle = *D*-*allo*-isoleucine

Pro = *L*-proline

Pip = pipercolic acid

Oxopip = 4-oxopipercolic acid

Hypro = *L*-hydroxyproline

Oxopro = *L*- γ -oxoproline

Sar = sarcosine

MeVal = *L*-*N*-methylvaline

Me-*a*-lle = *L*-methyl-*allo*-isoleucine

MeAla = *L*-*N*-methylalanine

Table I lists the amino acid sequences in chain α and chain β .

If one considers actinomycin C₁ as the basic structure, all other variations can be derived either by methylation

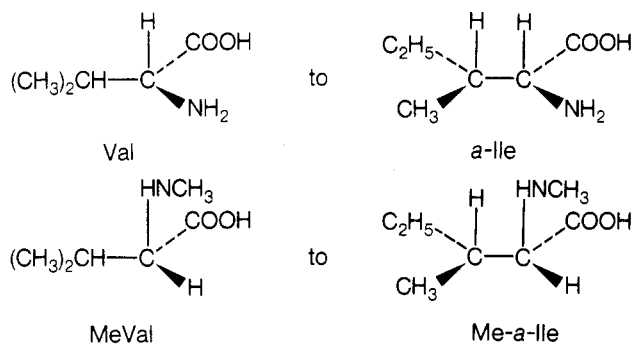

or by oxidation

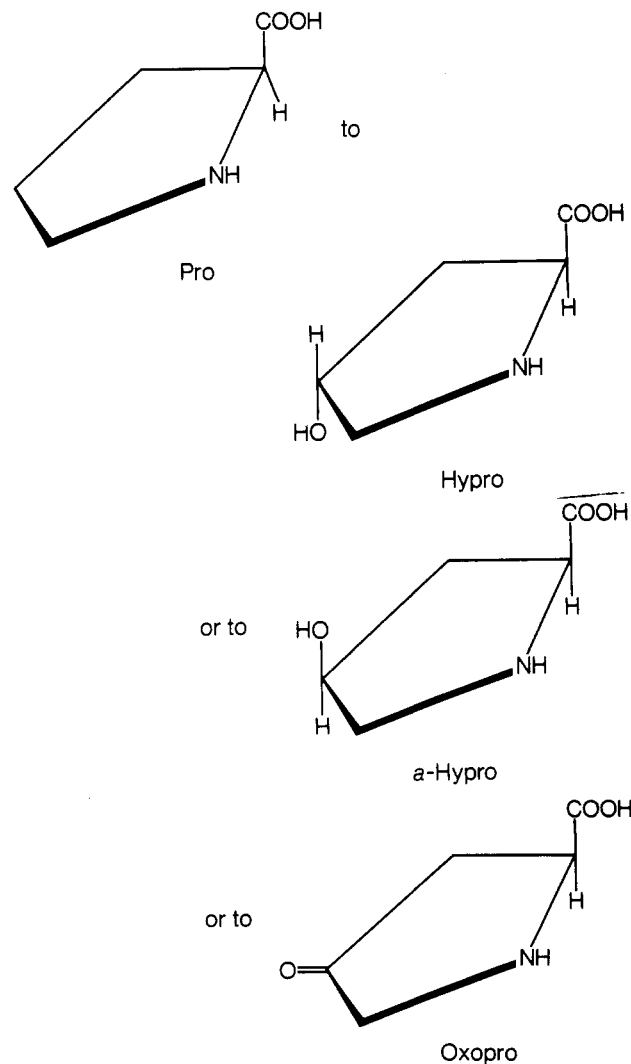

or by replacement of Pro by Sar(CH₃NHCH₂COOH), while Thr always remains unchanged.

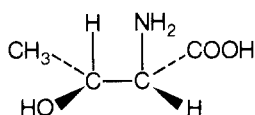

Table II depicts the relationships between various actinomycins.

II. Synthesis

A. Biosynthesis

Many of the biosynthetic studies took place before 1960. Reviews cover this topic through 1967.²⁶⁻²⁸ There are nine major areas of study: (1) controlled biosynthesis; (2) biosynthesis of Val, *α*-Ile, 4-Oxopro, 4-Hypro, Sar, MeVal and MeAla; (3) derivation of the actinocin chromophore; (4) synthesis of the pentapeptides and linking of the pentapeptide; (5) lactone formation and time of occurrence during total biosynthesis; (6) the biogenetic relationship to similar polypeptide antibiotics (e.g., polymyxin, gramicidin); (7) relationship to protein synthesis; (8) role of the antibiotic in the metabolism of the organism producing it; and (9) simultaneous synthesis of several closely related actinomycins by the same organism.

Controlled biosynthesis, a technique of predetermining the structure of a new antibiotic by furnishing specific chemical precursors to the antibiotic producing microorganism, has been applied successfully to the formation of modified forms of actinomycin. If an amino acid, already present in actinomycin or similar in structure, is supplied exogenously to the culture medium, it competes with the endogenously synthesized amino acid and is incorporated into the peptide chain either with increased formation of a trace actinomycin component or with formation of a new actinomycin. Examples are two "new" actinomycins E₁ and E₂ which were formed in the presence of DL-Ile. In these compounds one or two molecules of MeIle replace one or two molecules of MeVal. Other modifying amino acids are Sar, pipercolic acid, azetidine-2-carboxylic acid, and methyl and halogenated prolines. For instance, *S. antibioticus* produces a mixture of actinomycins in the presence of pipercolic acid in which proline is replaced by the analog. The three new antibiotics are designated actinomycins Pip 1 α , Pip 1 β , and Pip 2. Pip 1 β and Pip 2 had molar ratios pipercolic acid/proline of 1:1 and 2:0, respectively. Pip 1 α contains one pipercolic acid and one 4-oxopipercolic acid.²⁹⁻³¹

Thr is presumably synthesized from aspartic acid, as in other organisms. Thr-¹⁴C supplied to *S. antibioticus* is incorporated. Surprisingly, L-Val is employed in preference to D-Val for the synthesis of peptide bound D-Val. Incorporation of L-Val-1-¹⁴C suggests that the carbon skeleton of L-val is employed for synthesis of D-Val. L-Val-1-¹⁴C is not an intermediate. Feeding experiments with L-Val-¹⁵N showed that the amino nitrogen of L-Val is retained during the inversion to the D isomer. A crude enzyme has been obtained which is probably involved in the activation of L-Val prior to incorporation into actinomycin.³²

Radioisotope experiments suggest the metabolic sequence L-Thr \rightarrow α -ketobutyrate \rightarrow L-Ile \rightarrow D- α -Ile. Pro is synthesized from glutamic acid, a pathway which is reversible. In contrast to mechanisms found in animals and plants, 4-Hypro does not arise from oxidation of peptide bound Pro but is directly incorporated. 4-Oxopro, which is also derived from Pro, is not an intermediate in the for-

TABLE I. Amino Acid Sequences in Different Actinomycins

Actinomycin	Chain	Amino acid				
		1	2	3	4	5
C ₁ (IV,D,I ₁ ,X ₁)	α	Thr	Val	Pro	Sar	MeVal
	β	Thr	Val	Pro	Sar	MeVal
C ₂ (VI,I ₂)	α	Thr	Val	Pro	Sar	MeVal ¹²⁵
	β	Thr	α -Ile	Pro	Sar	MeVal
C _{2a} (i-C ₂)	α	Thr	α -Ile	Pro	Sar	MeVal ¹²⁵
	β	Thr	Val	Pro	Sar	MeVal
C ₃ (VII,I ₃)	α	Thr	α -Ile	Pro	Sar	MeVal
	β	Thr	α -Ile	Pro	Sar	MeVal
II (F ₅)	α	Thr	Val	Sar	Sar	MeVal
	β	Thr	Val	Sar	Sar	MeVal
E ₁	α	Thr	α -Ile	Pro	Sar	[MeVal]
	β	Thr	α -Ile	Pro	Sar	[Me-Ile]
E ₂	α	Thr	α -Ile	Pro	Sar	Me-Ile
	β	Thr	α -Ile	Pro	Sar	Me-Ile
F ₁	α	Thr	[Val]	Sar	Sar	MeVal
	β	Thr	[α -Ile]	Sar	Sar	MeVal
F ₂	α	Thr	[Val]	[Pro]	Sar	MeVal
	β	Thr	[α -Ile]	[Sar]	Sar	MeVal
F ₃	α	Thr	α -Ile	Sar	Sar	MeVal
	β	Thr	α -Ile	Sar	Sar	MeVal
F ₄	α	Thr	α -Ile	[Pro]	Sar	MeVal
	β	Thr	α -Ile	[Sar]	Sar	MeVal
Pip/ α	α	Thr	Val	[Pip]	Sar	MeVal
	β	Thr	Val	[Oxopip]	Sar	MeVal
Pip/ β	α	Thr	Val	[Pro]	Sar	MeVal
	β	Thr	Val	[Pip]	Sar	MeVal
Pip 2	α	Thr	Val	[Pip]	Sar	MeVal
	β	Thr	Val	[Pip]	Sar	MeVal
X _{0α}	α	Thr	Val	[Sar]	Sar	MeVal ¹⁰⁰
	β	Thr	Val	[Hypro]	Sar	MeVal
X _{0β} (I)	α	Thr	Val	[Pro]	Sar	MeVal ¹⁰⁰
	β	Thr	Val	[Hypro]	Sar	MeVal
X _{0γ} (III,F ₉)	α	Thr	Val	[Sar]	Sar	MeVal ¹⁰⁰
	β	Thr	Val	[Pro]	Sar	MeVal
X _{0δ}	α	Thr	Val	[Pro]	Sar	MeVal ¹⁰⁰
	β	Thr	Val	[Hypro]	Sar	MeVal
X _{1a}	α	Thr	Val	[Sar]	Sar	MeVal ¹⁰⁰
	β	Thr	Val	[Oxopro]	Sar	MeVal
X ₂ (V)	α	Thr	Val	[Pro]	Sar	MeVal
	β	Thr	Val	[Oxopro]	Sar	MeVal
Z ₁	In unknown order: Thr, Val, MeAla, Sar, MeVal, 5-Me(?)4-Oxopro and an unidentified hydroxyamino acid ^{9,101}					

mation of 4-Hypro. Instead, in the formation of 4-Hypro the trans 4-hydrogen atom of proline is displaced by OH with complete retention of configuration.

Glycine is the direct precursor of Sar in actinomycins, with Gly-C₁ and Gly-C₂ going to Sar-C₁ and Sar-C₂, respectively, while some Gly-C₂ is used for the Sar-N-CH₃. L-Val is not only the precursor of D-Val but also of L-MeVal. The main source of the N-methyl in Sar and MeVal is methionine. It is not clear whether the methylation step takes place before or after incorporation of Gly and L-Val, respectively. However, in controlled biosynthesis Sar-¹⁴C is completely utilized.

Tracer experiments revealed the biosynthesis of the chromophore unit actinocin. The path proceeds from tryptophan via kynurenine, 3-hydroxykynurenine to 3-hydroxyanthranilic acid. The latter is methylated by methionine at the 4 position in a most unusual benzene methylation step to give 3-hydroxy-4-methylanthranilic acid.^{33,34} The enzymic synthesis of actinocin and of actinocinyl peptides has been accomplished with phenoxazinone synthetase.³⁵ This enzyme catalyzes the oxidative coupling of *o*-aminophenols to the corresponding phenoxazinone, regardless of the presence of 1-carboxyl, 1-car-

TABLE II. Relations between Actinomycins

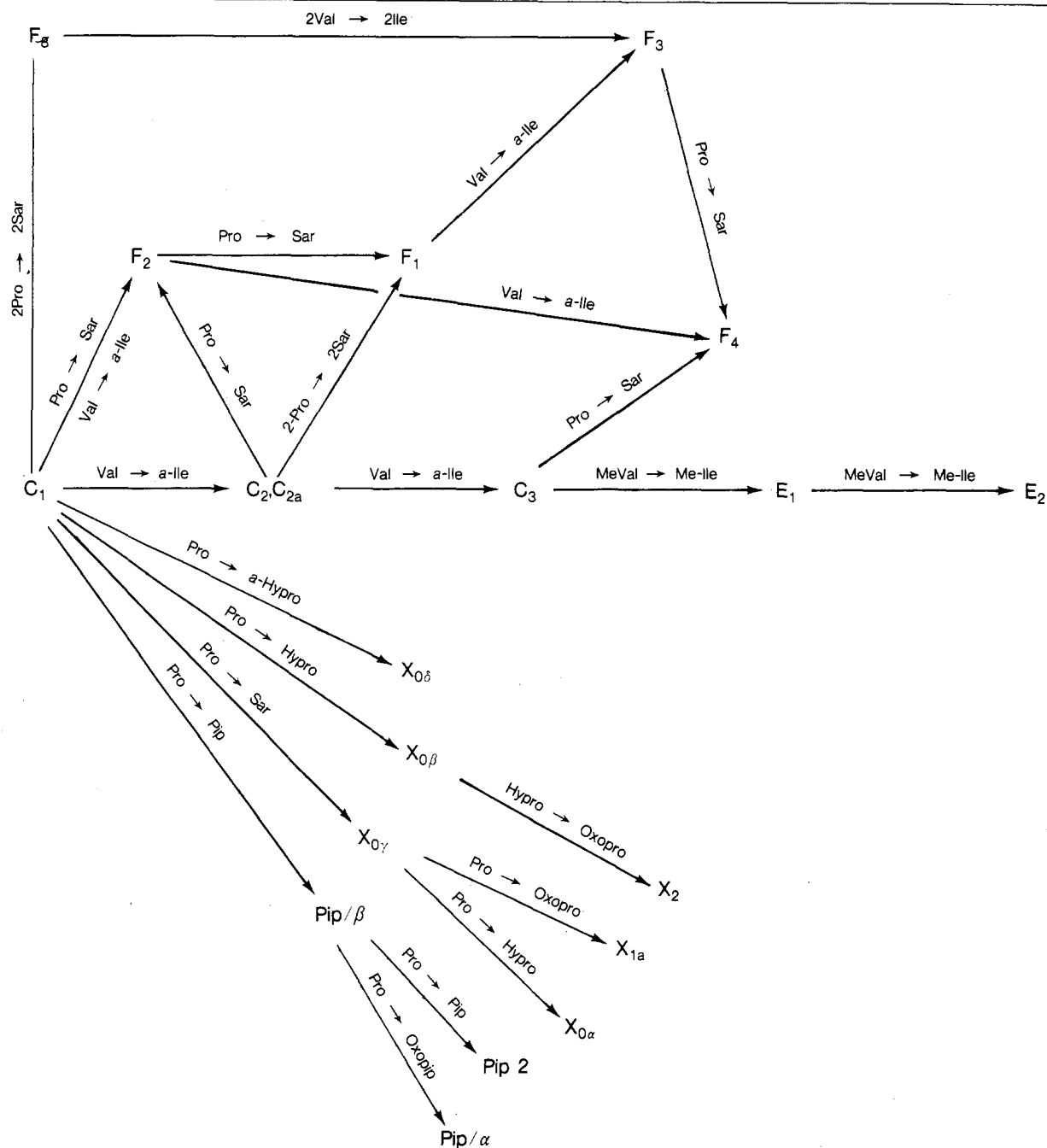

bonyl peptide, and 4-methyl, such as in 3-hydroxy-4-methylantranilic acid or -antraniloyl peptide. Three atoms of oxygen were utilized in the formation of one molecule of phenoxazinone. Figures 1, 2, and 3 depict the entire biosynthetic pathway.

About the synthesis of the peptide moiety itself little is known, although it is clear that, as in other peptide antibiotics, the pathway differs markedly from the mechanism known for protein synthesis. Also, the exact point at which two 3-hydroxy-4-methylantraniloyl units couple is not known. Possibly two such units couple and the amino acids are added in subsequent mechanistically obscure reactions, or the pentapeptide lactone is built up first on the monomer which then dimerizes. A number of polypeptides whose sequences are found in actinomycin D and their 4-methyl-3-hydroxyantraniloyl derivatives have been prepared as possible substrates.³⁶

B. Synthesis of Actinomycins

Brockmann is to be credited with the recognition that the actinomycin chromophore (3) could be biosynthes-

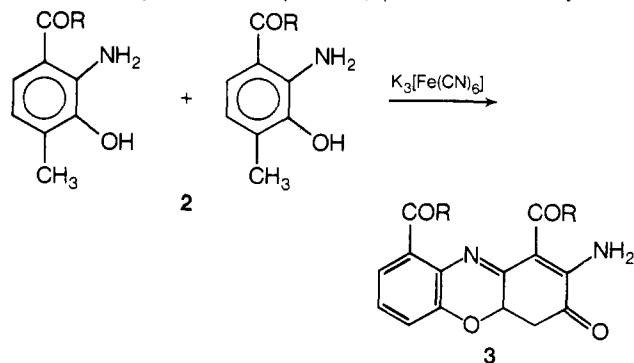

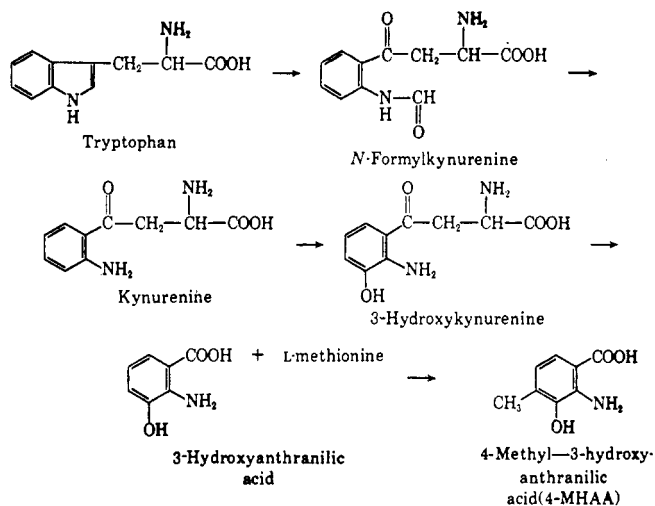

Figure 1. Biosynthesis of 4-methyl-3-hydroxyanthranilic acid from tryptophan and methionine.

ized from two identical 3-hydroxy-4-methylanthranilic acid moieties (2) by oxidative coupling, a hypothesis which was later confirmed.³⁵ He also succeeded in synthesizing this chromophore as well as actinomycin-like compounds truncated at the peptide chains, by such a biogenetic type dimerization, using potassium ferricyanide as oxidant.

The synthesis of actinocynylbis(L-threonines) 4 was accomplished by Brockmann³⁷ as follows:

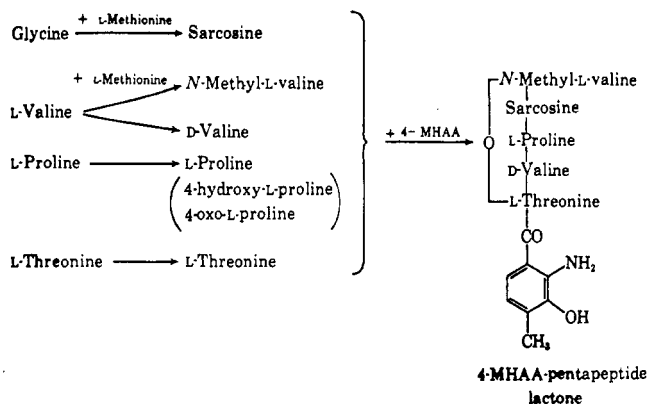
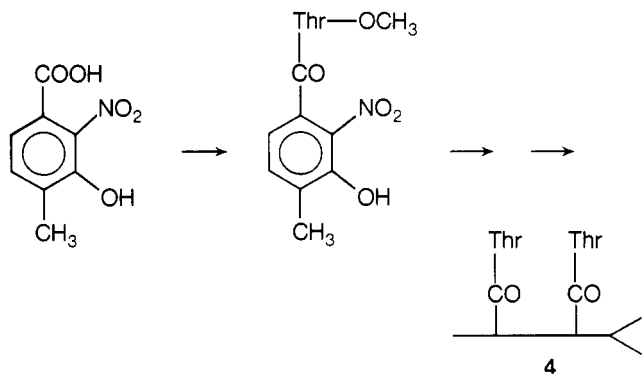

Figure 2. Biosynthesis of amino acid precursors from intracellular amino acid pool.

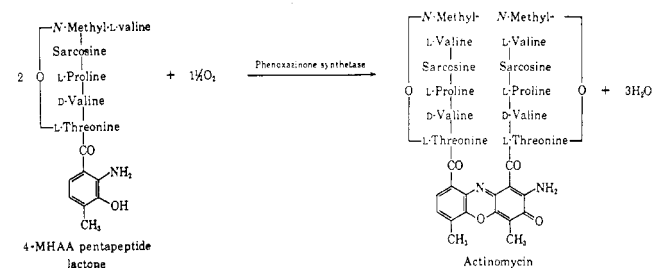

Figure 3. Oxidative condensation of two molecules of 4-MHAA pentapeptide lactone to form one molecule of actinomycin.

Deamination gave deaminoactinocynylbis(L-threonine) with NH_2 replaced by OH . The compounds were useful in identifying degradation products of natural actinomycins and as intermediates in later synthetic work.

The first structure confirming synthesis of an actual actinomycin could not be achieved at that time by the expected straightforward coupling of two ready-made monomeric units but was based on the serendipitous observation by Sunderkötter, that actinomycin C_3 could be hydrolytically cleaved between Sar and MeVal to give bis-(*seco*-actinomycin C_3) (5).³⁸

Actinomycin C_3 could be regenerated from the bis-*seco* compound,⁶ and the bis-*seco* compound could be synthesized by dimerization through oxidative coupling.³⁹ Thus, the first total synthesis of an actinomycin had been achieved and its postulated structure had been confirmed.

Brockmann synthesized several actinocynylbis(di- and tripeptides) in order to establish the identity of degradation products from actinomycin C_1 , C_2 , and C_3 .^{40,41} Two pathways were followed to the monomeric dipeptide (6) (Scheme 1). The same reactions were done with Val instead of *a*-Ile. Oxidative coupling of the two aminophenols, containing either *a*-Ile or Val, yielded the four bis-

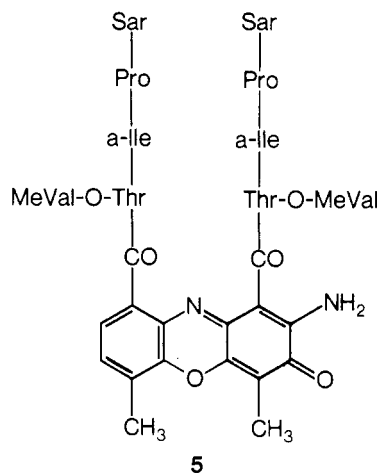

dipeptides, separable through cellulose or paper chromatography

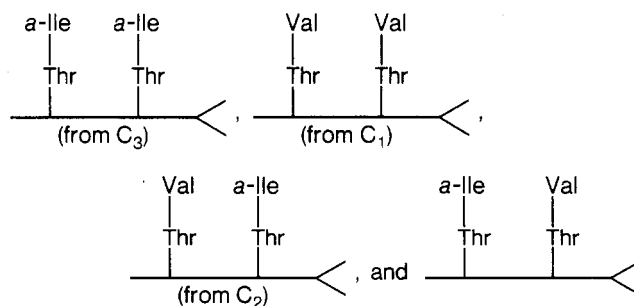

which in that order were identical with the degradation products from actinomycins C_3 , C_1 , and C_2 . The fourth one found no use in this work.

Identification of the third and fourth isomeric bis-dipeptides could be established by alkaline hydrolytic degradation to a 3-hydroxyanthranilic (7) and a 2,5-dihydroxybenzoquinone (8) fragment. To obtain the monomeric tripep-

SCHEME I

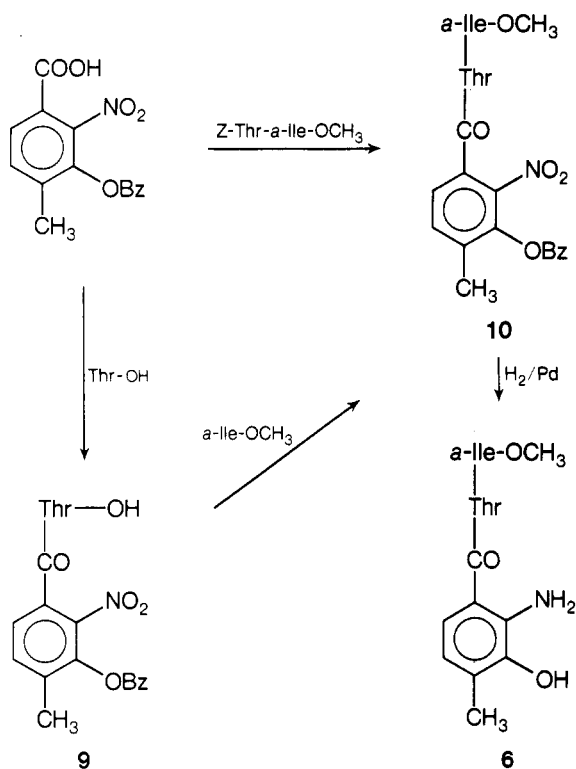

Compound 9 was coupled with a-Ile-Pro-OCH₃ or better 10 with Pro-OCH₃. No products in the hydrolyzate of actinomycin C₃ corresponded to the bis-tripeptide thusly synthesized.

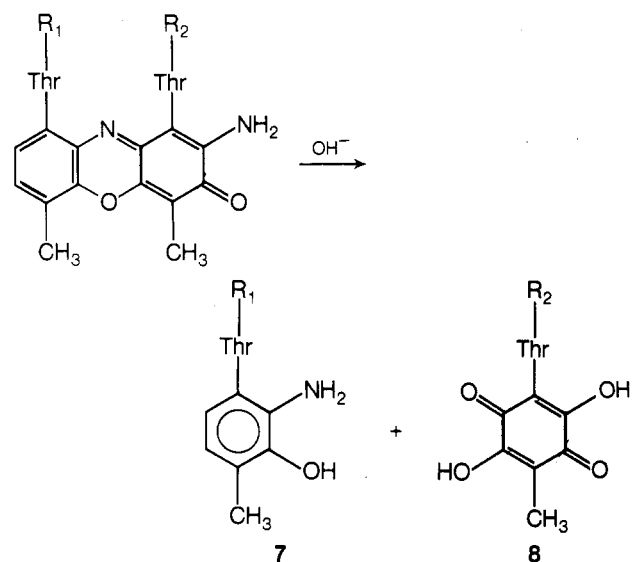

It was noticed that lengthening of the peptide chains attached to the phenoxazine becomes increasingly difficult with the number of amino acids present, and it is concluded that the bis-peptides are more advantageously synthesized by carrying out the oxidative dimerization as the last step. In principle, there are several ways in which an actinomycin can be synthesized,⁴²⁻⁴⁶ as shown in Table III.

After weighing the disadvantages against advantages, path E was chosen for the synthesis of the isoactinomycins and path D for the synthesis of the anisoactinomycins.²⁶⁻²⁸ Path C-1 was found to be particularly disadvantageous. Only a few per cent yield was achieved. Brockmann ascribed this result to a steric hindrance in the approach of the amino group of one peptide chain to the

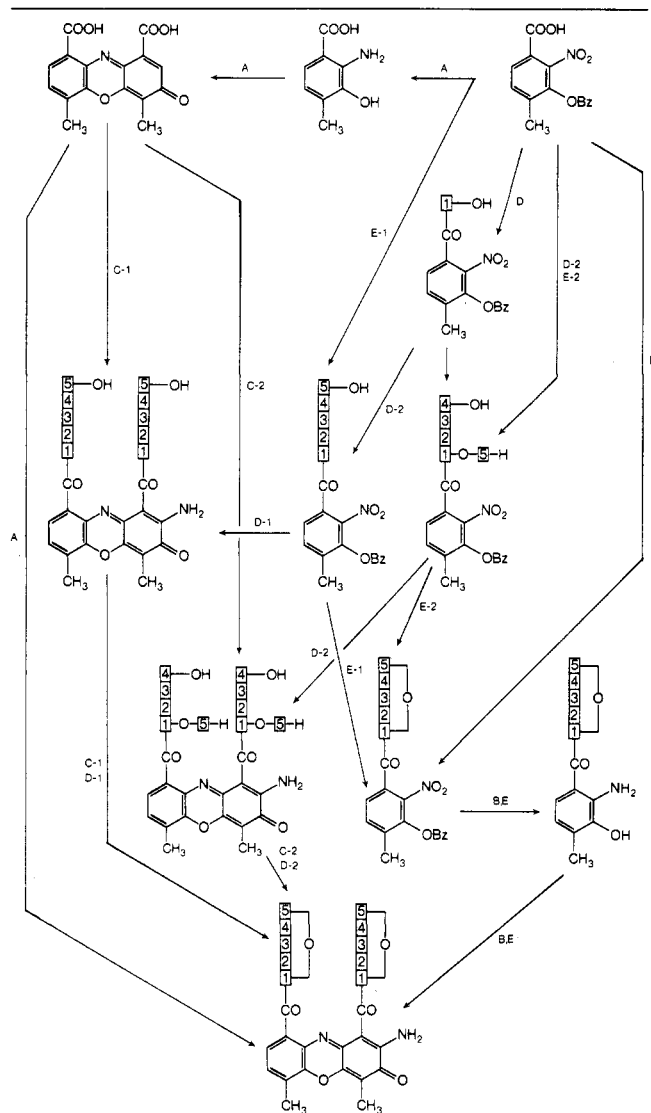
TABLE III. Pathways for the Synthesis of Actinomycins^a

^a Path A: Connection of two intact lactone rings with actinocin, prepared by oxidative dimerization. Path B: Connection of an intact lactone ring with the monomeric unit, followed by oxidative dimerization. Path C: Connection of two peptide residues either in the open pentapeptide chain (C-1) or with amino acid 5 esterified with 1 (C-2) to actinocin followed by cyclization to the lactone rings. Path D: Building up of one pentapeptide chain (D-1) or one tetrapeptide esterified at 1 with 5 (D-2) on the monomeric unit, followed successively by oxidative dimerization and lactonization. Path E: Building up of one pentapeptide chain (E-1) or one tetrapeptide (E-2) esterified with 5 at 1 to the monomeric unit, followed successively by lactonization and oxidative dimerization.

bulky actinocin and an even more severe steric hindrance to the approach of the second peptide chain.

The same difficulty was experienced by Brockmann in his first actinomycin synthesis (C₃) via bis(*seco*-actinomycin), when an attempt was made to esterify the two Thr hydroxyls on the actinocinyl residue with two MeVal molecules. The bis-*seco* compound (11), however, was obtained in high yield via pathway D-2/E.

In the synthesis of the required monomeric unit two pitfalls were avoided: (i) stepwise construction of the tripeptide which gave ever decreasing yields, and (ii) coupling of a ready tetrapeptide which would mean exchange of the amino protective group against the benzoic acid residue. The latter residue was therefore used as protective group for Thr and the resulting compound 12 was coupled with a-Ile-Pro-Sar.

Brockmann used *N*-formyl and benzyl ester protective

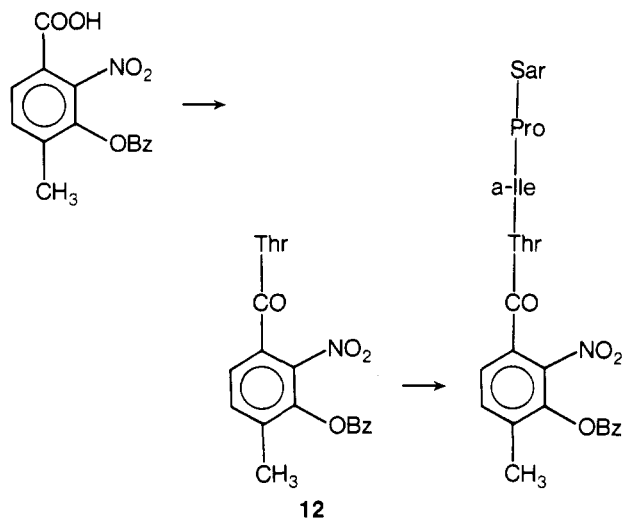
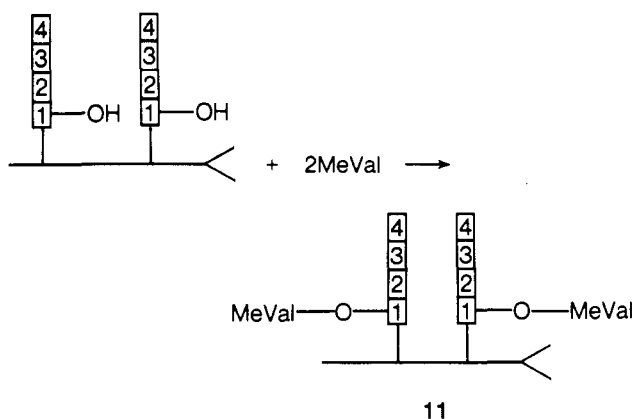

groups. Coupling was achieved with dicyclohexylcarbodiimide (DCCI) or, better, to the Thr residue with Woodward's reagent.⁴⁷ The esterification of the Thr-OH with MeVal could best be achieved with *N,N'*-carbonyldiimidazole.⁴⁸ The final coupling of MeVal to Sar was done with ethyl chloroformate.⁴⁹ The total yield was 0.13%, later improved to 2%.

Another pathway for the synthesis of actinomycins was visualized by Brockmann, when he found that the two lactone rings could be opened with 99.2% methanolic 4 *N* sodium methylate^{50,51} without destruction of the peptide chains and the chromophore, but with partial racemization, probably of the MeVal residue. The resulting actinomycinic acid (15) could function as an intermediate in an actinomycin synthesis. Unlike esterification to the bis-*seco* compound with carbonyldiimidazole, the esterification (=lactonization) of actinomycinic acid was not successful with this reagent, nor with its thionyl analog, presumably because of steric inhibition of the esterification of the Thr hydroxyl with the bulky azolide group. Fortui-

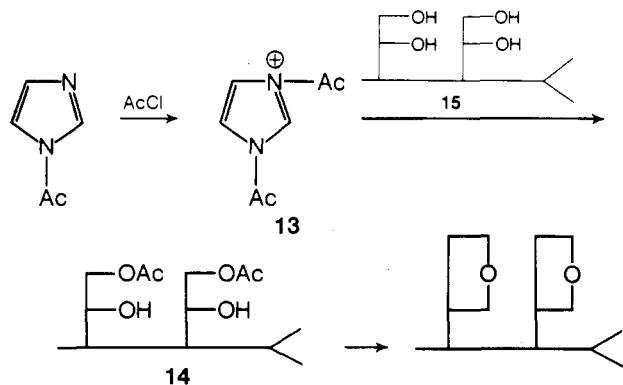

tously, an equimolar mixture of acetylimidazole and acetyl chloride was found to be an effective lactonizing agent. Brockmann explains the reaction to take place via 1,3-diacetylimidazolium chloride (13) and the mixed anhydride of acetic acid and actinomycinic acid (14).

The success of this reaction is further ascribed to the sterically facile formation of the mixed anhydride as opposed to the sterically hindered acetylation of the Thr hydroxyl. Although it is not a major pathway, lactonization between carboxyl and hydroxyl of different peptide chains cannot be excluded.

When Brockmann had learned how best to lactonize actinomycinic acids, a new synthetic pathway could be applied to the total synthesis of several actinomycins.⁵²⁻⁵⁴ The new method yielded 20-30% yields, as compared to the older bis(*seco*-actinomycin) route with 3-4% yield.

The general reaction scheme is given in Scheme II.

SCHEME II

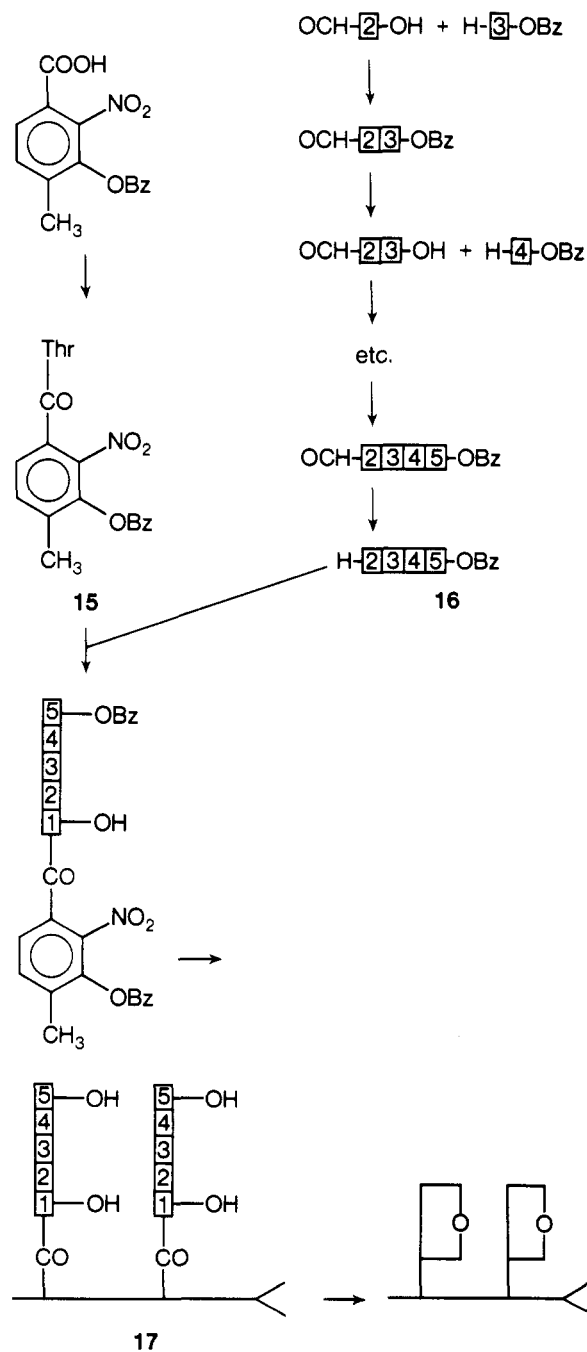

A Thr residue is coupled to the monomeric unit (15). This step was also done with D-threonine, L-serine, and L-Thr-Gly. The required tetrapeptide (16) is then synthesized, starting with amino acid [2], blocked with formyl, and amino acid [3] in its benzyl ester form. The dehydrating agent is DCCl. After hydrogenolysis of the dipeptide [2][3], amino acids [4] and [5] are added successively, repeating the same steps. The intact tetrapeptide with its free amino end and benzyl ester block is coupled to the Thr residue in 60–80% using Woodward's reagent.⁴⁷ Hydrogenation followed by immediate oxidative coupling with potassium ferrocyanide yields the actinomycinic acid (17) in 53–90% yield. Brockmann obtained ten isoactinomycinic acids, a mixture of two isomeric anisoactinomycinic acids, one actinocinylbis(pentapeptide), and one actinocinylbis(hexapeptide). This set

of compounds contained the precursors for actinomycin C₁ and C₃ as well as variations in amino acid configuration and structure and addition of a sixth amino acid (Gly).

Final cyclization, *i.e.*, lactonization, with acetyl chloride/*N*-acetylimidazole of the appropriate actinomycinic acids led to actinomycin C₁ (D) (first total synthesis) and to actinomycin C₃ (second total synthesis). Also a nonseparable mixture of the anisoactinomycin C₂ and its position isomer *i*-C₂ (C_{2a}) was obtained.

Of interest furthermore were the generation of a set of new actinomycins, some of which showed biological activity. There were obtained: an analog of C₃ with D-Leu instead of D-*a*-Ile, an analog of C₁ with L-Ser instead of L-Thr, and an analog of C₁ or C₃ with D-Ala instead of D-Val or D-*a*-Ile.

These and further lactonization experiments revealed the following rules: cyclizations will only give worthwhile yields if (i) variations are limited to the alkyl residues of amino acids [1], [2], or [5] and (ii) if the peptide chain has the natural sequence of configurations LDLL or its enantiomers DLDD. Apparently easy cyclization requires a certain favorable conformation of the 15-membered pentapeptide chain which in turn is predetermined by the alkyl residues and the configurations. Perhaps this is the reason for the "unnatural" D configuration in amino acid [2]. Presumably, these conditions were advantageous in Brockmann's syntheses *via* actinomycinic acids, because diastereoisomeric intermediates, formed by partial racemization, were not converted to the lactones and, thus, Brockmann's products C₁ and C₃ were optically pure.

That actinomycins C₂ and *i*-C₂ are not chromatographically separable is not surprising:⁵⁵⁻⁵⁷ the position isomers with regard to Val and *a*-Ile have almost identical solubilities. Brockmann solved the separation problem by oxidatively coupling a mixture of an open-chain benzoylpeptide and a lactonized benzoylpeptide (Scheme III). The four products (18, 19, 20, 21) could be easily separated. Thus, by choosing an appropriate combination of open chain and lactonized monomer, one can obtain any desired anisoactinomycin.

The oxidative coupling of two *o*-aminophenols to the actinomycin chromophore, as developed by Brockmann in yields of 90%, proceeds presumably by attack of the amino group of one monomer onto the position para to oxygen in the other monomer which reacts in the oxidized quinoid form, followed by attack of oxygen on the position para to the amino group⁵⁸ (Scheme IV). Apparently a condensation in reverse direction to a phenoxazim (22) is not a noticeable competing pathway.

Brockmann investigated the same reaction for monomers which had the substituents R₁ and R₂ reversed.^{25,59} Surprisingly the reaction in reverse direction was now predominant. Oxidative coupling of air-stable 3-amino-2-hydroxy-4-methylbenzoic acid methyl ester (23) with ferric chloride gave 13% of the expected pseudoactinocin dimethyl ester (24) and 53% of the phenoxazim (25) which was isolated as the hydrolysis product of the 2-deamino-2-hydroxyactinocin structure (26). The latter could be converted to the corresponding 2-amino-3-phenoxazone (27) (Scheme V).

Likewise, the oxidative dimerization of *N*-(3-amino-2-hydroxy-4-methylbenzoyl)-L-threonine methyl ester (28) gave 21% of the desired pseudoactinocinylbis(L-threonine methyl ester) (29) and 19% of the "wrong" 2-deamino-2-hydroxyactinocin (30). By reverting to the oxidative coupling reagent potassium ferricyanide and acetylating the threonyl hydroxyl, much better results were obtained: 65% pseudoactinocinylbis(*O*-acetyl-L-threonine methyl

SCHEME III

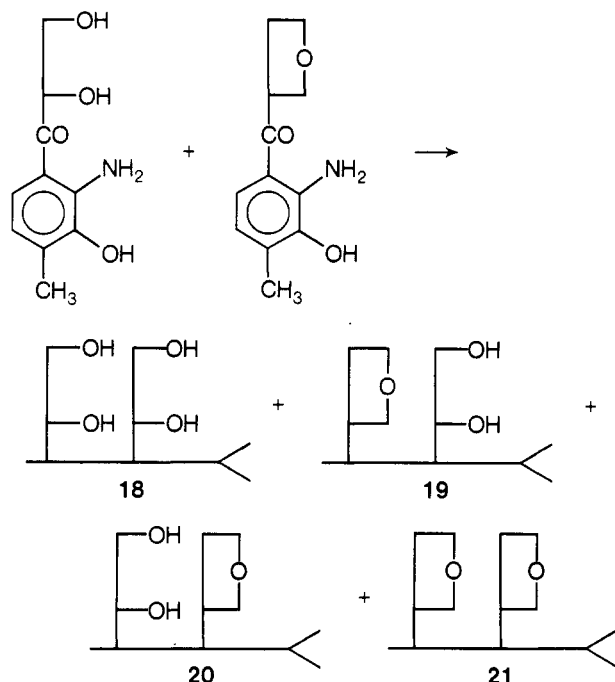

SCHEME IV

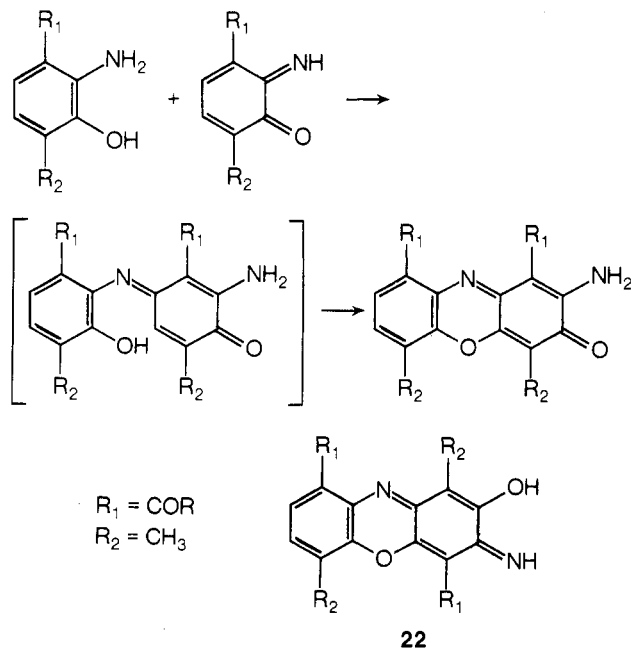

SCHEME V

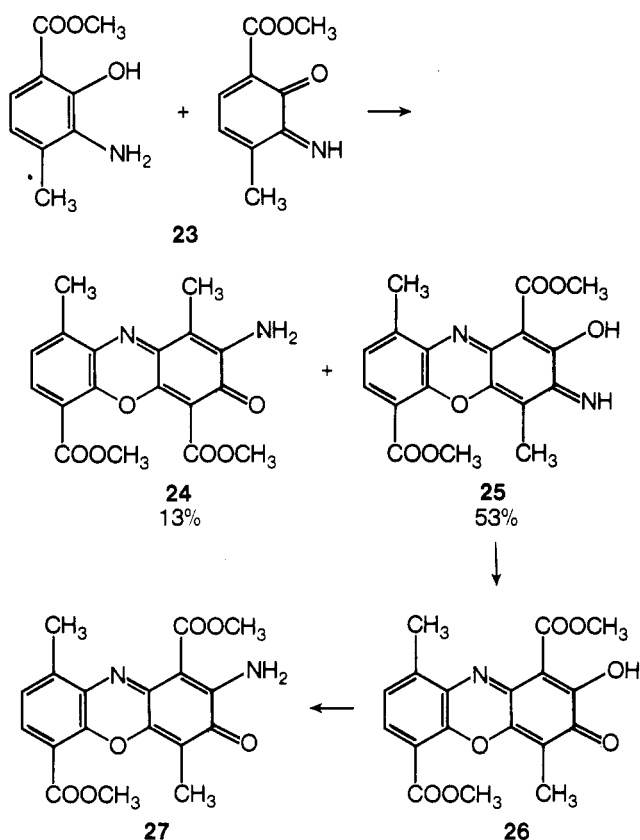

ester) and 26% of the corresponding "wrong" 2-deamino-2-hydroxyactinocin.

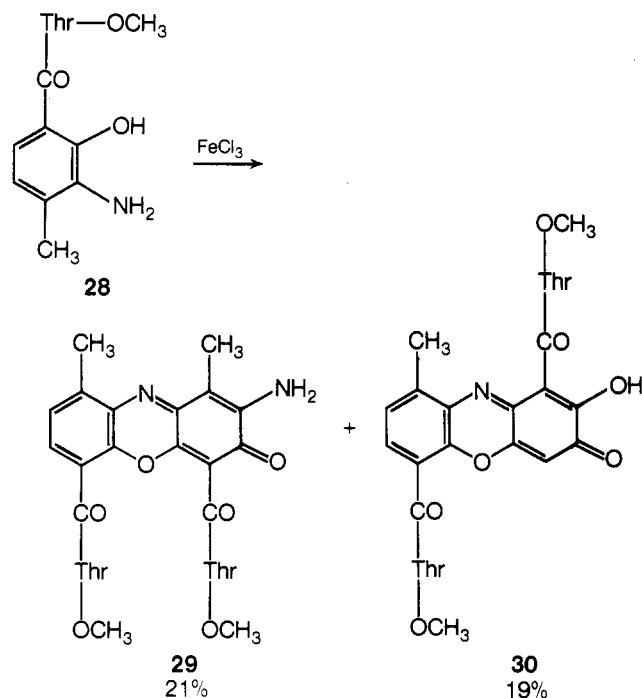

The presence of significant amounts of the phenoxazin products in the condensation of monomers in which the COR and CH₃ groups are interchanged can be explained by simple considerations involving reinforcing or opposing interplays of resonance and inductive effects on the C=C—C=N and C=C—C=O system.⁵⁸

It was now of importance to develop a synthetic method which allowed for separate formation of two isomeric anisoactinomycins. For this purpose Lackner synthesized

SCHEME VI

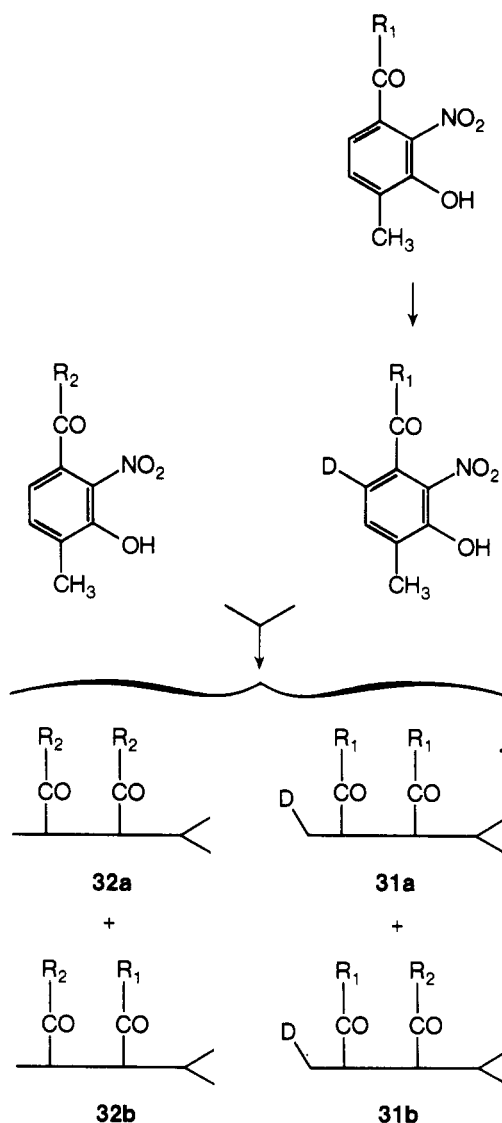

anisoactinocinylpeptide pairs with an incomplete bis-pentapeptide lactone moiety.^{25,59}

Upon deuteration of the monomeric unit in the 6 position, oxidative coupling in admixture with a nondeuterated monomeric unit differing in the peptide moiety produced four products: two isoactinomycins (**31a**, **32a**) and two isomeric anisoactinomycins (**31b**, **32b**). In each pair one compound is deuterated (see Scheme VI). When R₁ = OCH₃ and R₂ = Thr-OCH₃ the two aniso compounds could be separated from the iso compounds and from each other. Their structures could be easily assigned from the nmr spectrum of the deuterated and the nondeuterated compound. Upon extending the chains to R₁ = Thr-Val-OCH₃ and R₂ = Thr-*a*-Ile-OCH₃ the mixture of aniso compounds could still be separated and structures could be assigned with nmr. Knowing that the full pentapeptide chains in isomeric anisoactinomycins would not allow for separation, Lackner synthesized isomers with large differences in the α and β chain. The isomeric mixture with R₁ = OCH₃ and R₂ = lactonized Thr-Val-Pro-Sar-MeVal-O- was separable. Attempts to separate the mixture with R₁ = open-chain pentapeptide methyl ester and R₂ = open-chain pentapeptide were unsuccessful. Separable was the isomeric mixture obtained with R₁ = open-chain pentapeptide methyl ester and R₂ = pentapeptide lactone. Nmr allowed again for assignment of structures. The isomeric mixture of the bis-pentapeptide

SCHEME VII

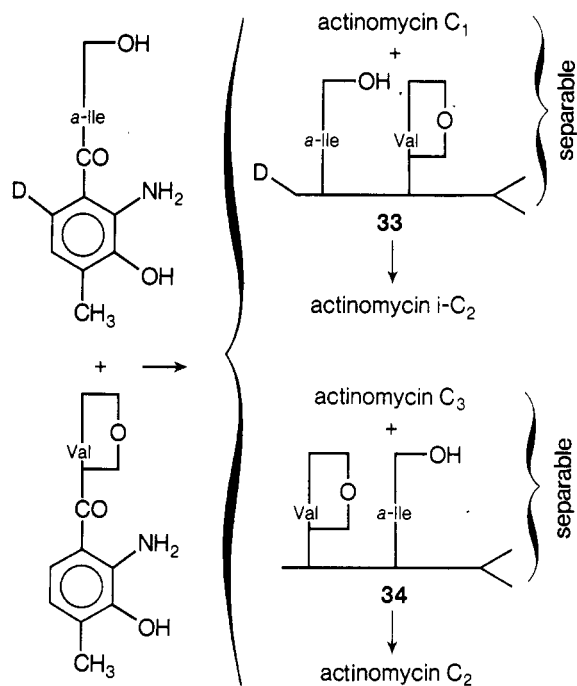

lactones deuterioactinomycin *i*-C₂ and actinomycin C₂, however, could not be separated. It had now become clear that separation of aniso isomers must be accomplished at the intermediate stage in the synthesis. The synthesis of individual actinomycin C₂ and *i*-C₂ was finally achieved via the separable mixture of isomeric actinomycinic acid-monolactones (**33**, **34**, Scheme VII). Thus, for the first time the components of a nonseparable isomeric aniso mixture had been obtained pure and their structure assigned unambiguously. For the study of the interaction of the two peptide rings with each other as well as with DNA the conformation had to be known. For

SCHEME VIII

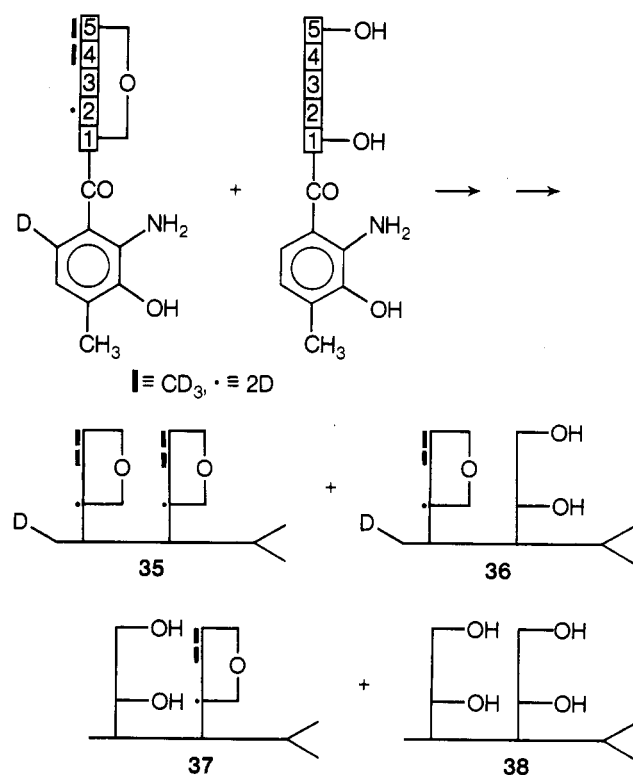

this purpose Lackner synthesized selectively deuterated pentapeptide lactones and coupled these to actinomycins deuterated in the α or β peptide ring.⁶² Only then can absorptions be assigned to the α or β position. The actinomycins **35**, **36**, **37** and **38** were synthesized via suitable oxidative couplings of one lactonized monomer with one open-chain monomer, separation, and lactonization of the second chain, as shown earlier (Scheme VIII).

A conformation of the monomeric unit has been proposed.⁶³ To assign the actinomycin C₁ signals, only the spectra of selected iso- and anisodeuterioactinomycins were needed.

An approach different from Brockmann's was followed in a synthesis of actinomycin D (C₁) whereby the pentapeptide was built up stepwise starting with MeVal-*t*-OBu and coupled to 2-nitro-3-benzyloxy-4-methylbenzoic acid *N*-hydroxysuccinimide ester (**39**) in 53% yield. Actinomycinic acid **40** was obtained after hydrogenation and oxidative dimerization. Cyclization to the bis-lactone proceeded only with poor yields.⁶⁴

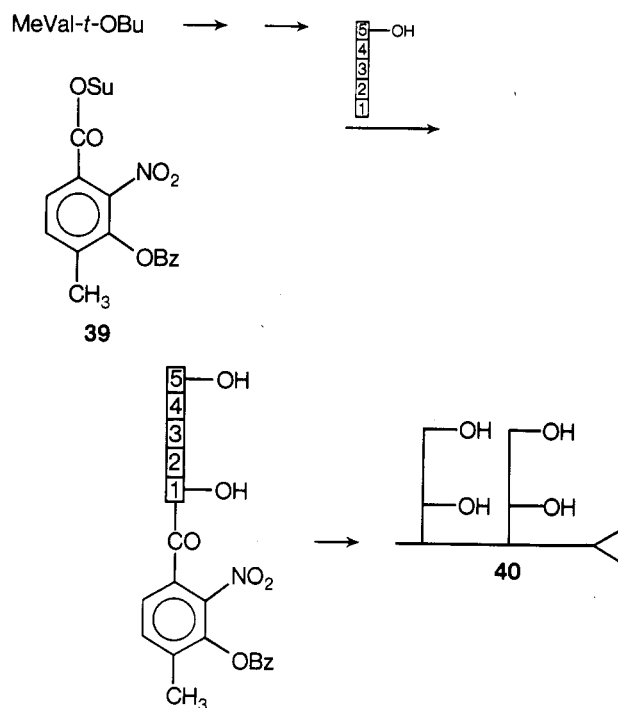

In another approach actinomycin D (C₁) was formed by coupling of a preformed

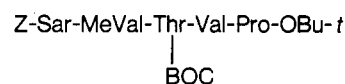

chain to the substituted benzoyl chloride to give **41**, followed by hydrogenation and oxidative coupling in 80% yield.¹

C. Proof of Two Pentapeptide Lactone Rings

Earlier degradative studies on actinomycins had not unequivocally demonstrated whether the ten amino acids belong to two pentapeptide lactone rings or to a decapeptide-dilactone ring. The latter possibility had been tacitly ignored on biogenetic grounds, although space-filling models allow for considerations in favor of the decapeptide ring.⁶⁵ Brockmann presented two independent proofs of the bis-pentapeptide structure, after attempts through X-ray structure analysis had failed.⁶⁶

The first proof proceeded via degradation.^{67,68} Actino-

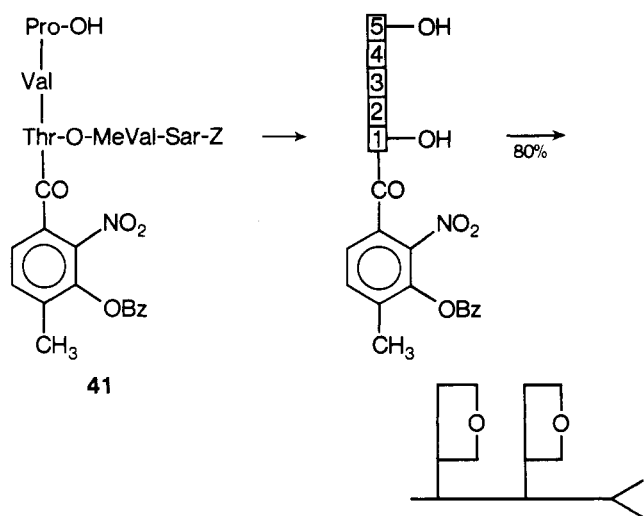

mycin C₃ was converted into its 2-deamino-2-hydroxy derivative (42) and oxidation of the latter with acetic acid–30% hydrogen peroxide yielded an *N*-oxalylpentapeptide lactone (43) and not a dioxalyldecapeptide dilactone (44), a distinction which could be made on the basis of cryoscopic and mass spectral molecular weight determinations of the corresponding methyl ester (Scheme IX)

SCHEME IX

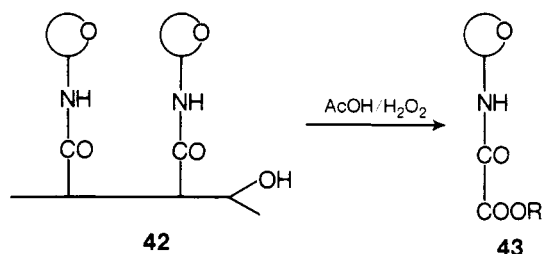

and not

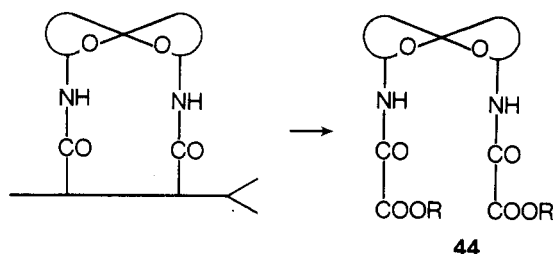

Actinomycin C₂, for which the position of Val in the α -sequence and *a*-Ile in the β -sequence had been proved,^{25,40,41} yielded upon similar treatment an *N*-oxalylpentapeptide lactone containing *a*-Ile. Apparently the *N*-oxalyl derivative is cleaved only from the quinoid ring. This result obviates a molecular weight determination. Moreover, this finding opens a road to the amino acid position determination in anisoactinomycins, provided the β -peptide ring does not contain oxidizable amino acids such as hydroxy- and oxoproline. Brockmann presents solid arguments, in part based on experimental data, against the possibility of a transition of a decapeptide to a more stable bis-pentapeptide during any of the phases of the degradative–oxidative procedure.

In a second procedure Brockmann proceeded *via* synthesis. He not only provided a second independent proof for the bis-pentapeptide lactone structure, but at the same time presented a novel approach to the synthesis of actinomycins^{55–57} according to path E discussed above; that is, the lactonization is accomplished before

oxidative dimerization. Synthesis of the protected tetrapeptide CHO-[2345]-OCH₃ was done as before and the fragment was coupled to *N*-(2-nitro-3-benzyloxy-4-methylbenzoyl)-L-threonine with Woodward's reagent.⁴⁷ Hydrolysis of 5-methyl ester 45 was followed by lactoniza-

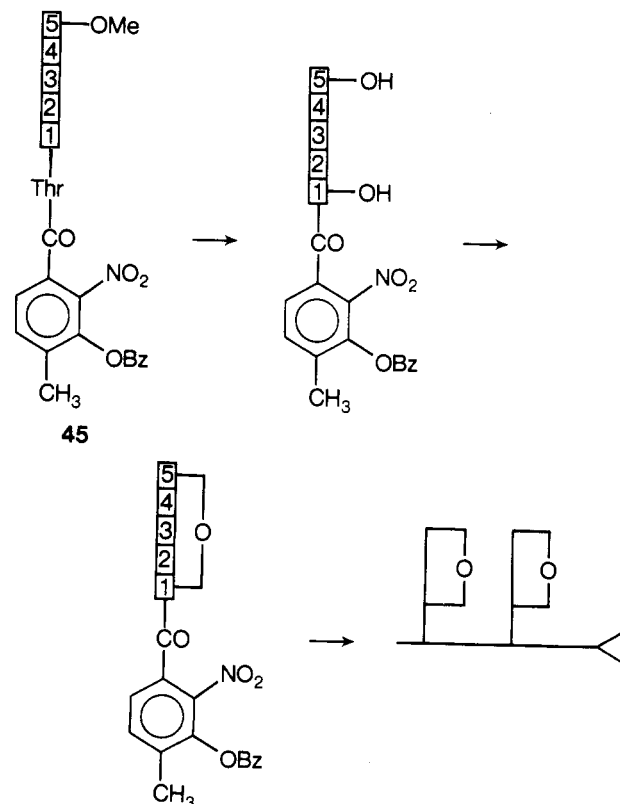

tion, again through the advantageous use of acetylchloride–acetylimidazole. Oxidative coupling of the appropriate monomers gave actinomycin C₁, C₃, and a nonseparable mixture of actinomycins C₂ and *i*-C₂. Again it must be assumed that the pentapeptide lactones remain unaltered after the oxidative condensation and are not transformed into a decapeptide–dilactone ring. This assumption is reasonable because such a transition would require a sterically improbable and unprecedented four-center transesterification. There remains the possibility that during the monomer lactonization step a decapeptide–dilactone (46) was formed. This could be ruled out

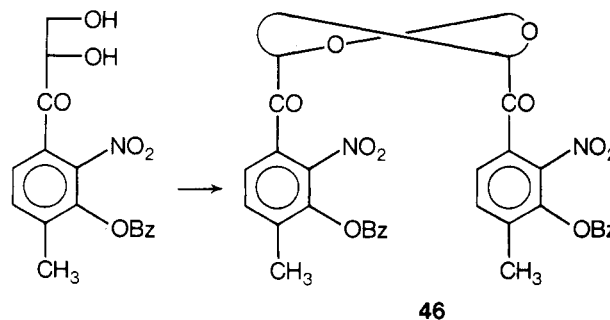

for two reasons: (i) the osmotic molecular weight determination of the lactonization product was in agreement with a monobenzyl-monopentapeptide lactone, and (ii) oxidative coupling of the equimolar mixture of the monomeric pentapeptide lactones containing for amino acid [2] Val or *a*-Ile should give equimolar amounts of actinomycins C₁ and C₃ and the cross products C₂ and *i*-C₂, while with the decapeptide–dilactone derivative oxidative coupling would merely yield actinomycins C₁ or C₃. The former case was observed.

D. Synthesis of Actinomycin Analogs

Because of the antibiotic action of the actinomycins, attempts have been made to improve the chemotherapeutic index by altering the actinomycin molecule. The alterations have been done (i) on the peptide chain, (ii) on the chromophore, and (iii) on the peripheral groups of the chromophore. The biological activities of these analogs are listed in Table IX, section VIII.

1. With Different Peptide Groups

The existing peptide chain can be modified, *viz.*, reduction of the oxyproline carbonyl,⁶⁹ esterification of the hydroxyproline residue,^{69,70} or by entirely new buildup of the peptide chain, such as actinomycin (L-Ser-D-Val-L-Pro-Sar-L-MeVal)⁷¹ and the optical antipode of actinomycin C₁ (D).⁷²

An actinomycin analog to C₁ with L-Ser instead of Thr was synthesized by Brockmann⁷¹ from benzoylserine + tetrapeptide, oxidative coupling, and lactonization.

Actinomycin D lactam (**49**), an analog in which the threonine oxygen (L-hydroxyl) is replaced by NH, was obtained *via* the stepwise buildup of Sar-MeVal-Thr*-Val-Pro (Thr* = L-threo- α,β -diaminobutyric acid) which was cyclized to the lactam (**47**) and coupled to the substituted benzoyl moiety in the anhydride form (**48**) followed by the usual steps (Scheme X). The analog was biologically active.^{73,74}

SCHEME X

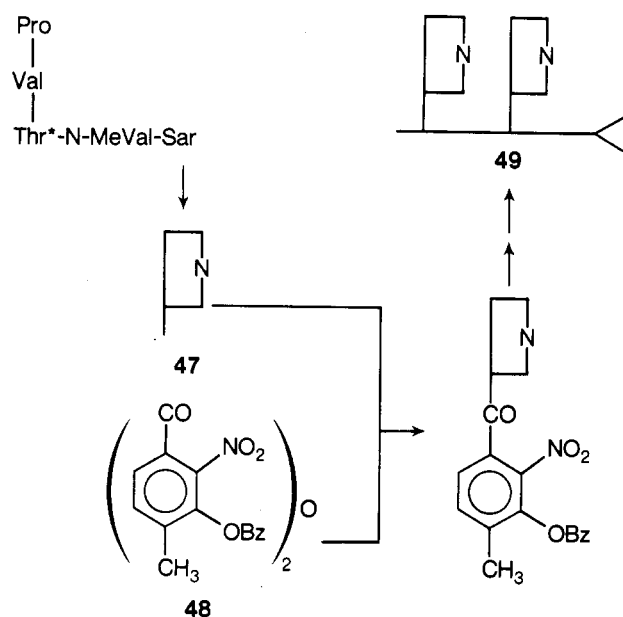

An analog of actinomycin D, lacking the four *N*-methyl groups ([4',4'-bis(glycine)-5',5'-bis(valine)]actinomycin D) was secured by cyclizing the preformed pentapeptide L-Thr-D-Val-L-Pro-Gly-L-Val and coupling of this lactone to the benzoyl moiety, followed by the usual reduction and oxidative coupling. The CD spectrum of the product in hexafluoroacetone indicates a conformation very similar to that of actinomycin, but different if taken in methanol, chloroform, and acetonitrile solutions. The compound showed no biological activity.⁷⁵

2. With Different Chromophore

One attempt has been made to synthesize an actinomycin sulfur analog with a different chromophore skeleton.⁷⁶ The synthesis was not carried beyond the 4,6-phenoxathiindicarboxylic acid.

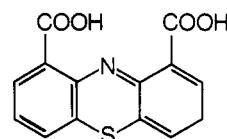

3. With Different Peripheral Groups on the Chromophore

Intensive studies have been carried out with regard to a change in the C₂-NH₂ group.

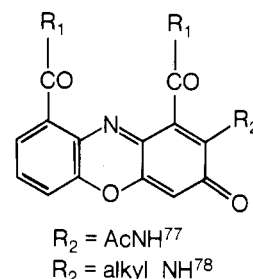

A group of *N*-substituted compounds, shown in Table IV, which could be obtained *via* the 2-deamino-2-chloroactinomycins,⁸¹ was of particular interest since several substitution products photochemically reverted to the corresponding actinomycin. It was hoped that the less active or inactive derivatives could penetrate into the tumor where they, upon irradiation, would be converted to actinomycin. None of the derivatives possessed an antibiotic, cytostatic, or toxic activity which even approached that of the corresponding actinomycin.

TABLE IV. Synthetic C₂-N-Substituted Actinomycins

Actinomycin C ₃	Actinomycin C ₂

The photolysis of *N*-alkylated derivatives of actinocin dimethyl ester has been investigated.^{82,83}

Since models for the interaction of actinomycin with DNA had been postulated, whereby the chromophore moiety is inserted between two adjacent base pairs along the double helix, it became of interest to modify the peripheral groups on the chromophore to see how the biological activity would be altered. Brockmann synthesized actinomycin C₁ analogs whereby the 4- and 6-methyl groups are substituted by H, OCH₃, C₂H₅, and C(CH₃)₃.⁸⁴⁻⁸⁶ The synthesis proceeded *via* the route: substituted benzoyl-Thr + tetrapeptide → monomeric unit → actinomycinic acid → actinomycin. Preliminary tests with the *tert*-butyl substituted benzoylmethyl ester showed an aberration of the usual pattern: oxidative coupling not only produced the 2-amino-3-phenoxazone (50) but also the benzoquinone anil (51).

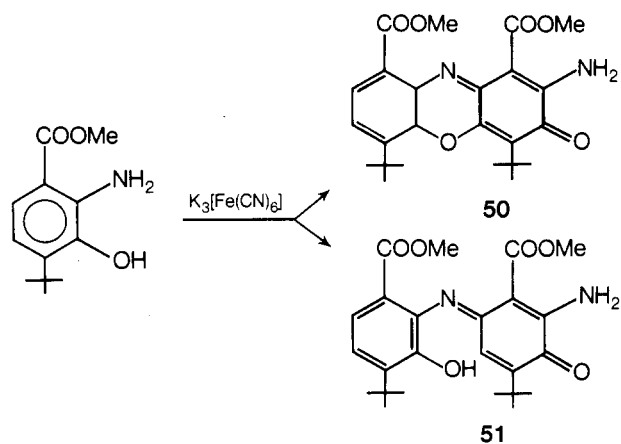

Adding the Thr-OCH₃ or the complete pentapeptide to the *tert*-butyl substituted monomer prevents formation of the phenoxazone entirely, and only the benzoquinone anils are formed. Cyclization of the latter could be achieved with trifluoroacetic acid. Isolation of the intermediate benzoquinone anils supports the earlier hypothesis that the oxidative coupling starts with addition of the amino group of one unit to the quinoid oxidation product of the other unit.

According to the model of the actinomycin DNA complex (see section VII), substitution of the 4- and 6-methyls by larger groups would be expected to hinder intercalation of the chromophore. This could be confirmed. The methoxyl group seems to be an exception; however, its behavior can be explained by hydration and concomitant energy loss of the binding energy. In addition it is possible that, because of the vicinity of hydrophobe DNA groups, the normal hydrophobic interaction with C₂H₅ or CH₃ is absent with OCH₃. It is surprising that the H analog has such a low activity. Again, the lack of hydrophobic interaction may play a role.

In view of the intercalative interaction of actinomycin with DNA, it was also of interest to synthesize actinomycin analogs substituted elsewhere in the chromophore. Brockmann found a facile entrance to the 7-position of the phenoxazinone chromophore.^{80,87} Reduction to the 3,10-dihydro derivative and condensation with pyruvic acid produced an oxazinone (52) whose 7-position could be oxidized (53, 54). After cleavage of pyruvic acid, the 7-hydroxyactinomycin C₂ (55) was obtained. Also the 7-nitro derivative (C₂) (56) could be obtained from the oxazinone (see Scheme XI).

Catalytic hydrogenation yielded the 3,10-dihydro-7-amino derivative (57) which was air oxidized to the 7-amino derivative (C₂) (58). The amino group of the

SCHEME XI

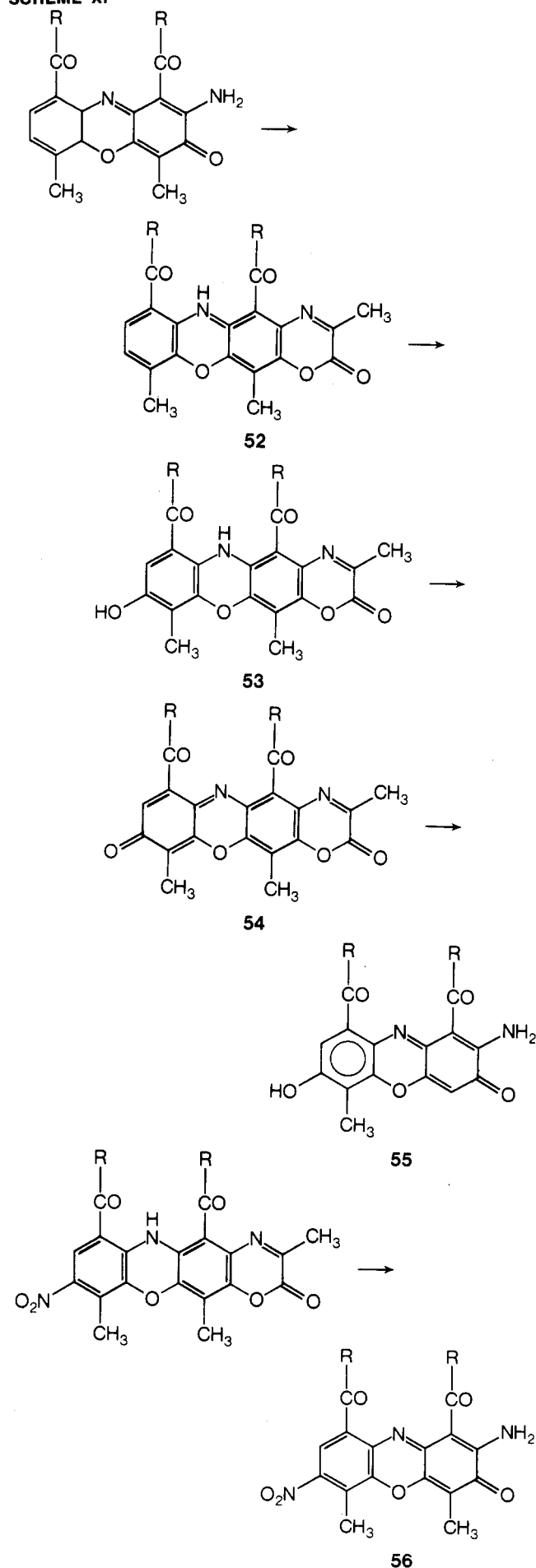

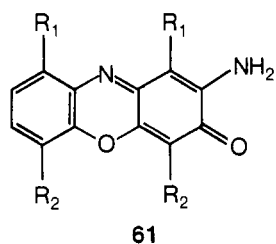
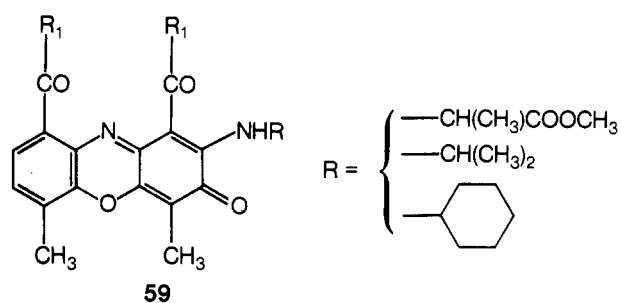
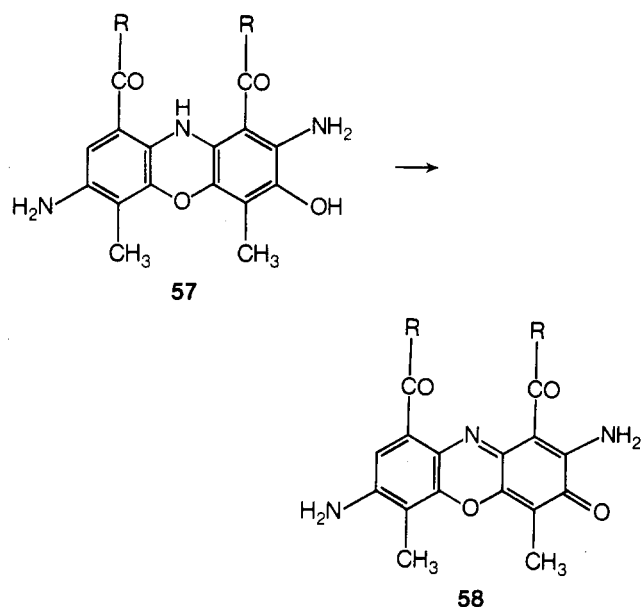

$\text{R}_1 = \text{COOH or COOMe}^{90}$

$\text{R}_2 = \text{Cl}$

$\text{R}_1 = \text{CONHCH}(\textit{i-Pr})\text{COOH or -COOEt}^{91,92}$

$\text{R}_2 = \text{Cl or Me}$

$\text{R}_1 = \text{CONH(CH}_2\text{)}_3\text{COOH or -COOEt}^{93}$

$\text{CONH(CH}_2\text{)}_2\text{COOH}$

$\text{CONH(CH}_2\text{)}_5\text{COOH}$

$\text{R}_2 = \text{Cl, or H}$

$\text{R}_1 = \text{COOEt}^{94}$

$\text{R}_2 = \text{Cl and Me}$

$\text{R}_1 = \text{CONHCH(COOH)(CH}_2\text{)}_4\text{NHAc}^{95}$

$\text{CONH(CH}_2\text{)}_4\text{CH(COOH)NHAc}$

$\text{CONH(CH}_2\text{)}_4\text{CH(COOEt)NHAc}$

$\text{CONHCH(COOH)(CH}_2\text{)}_4\text{NHCOOCH}_2\text{C}_6\text{H}_5$

$\text{CONH-}\alpha\text{'-(}\alpha\text{-piperidonyl)}$

$\text{R}_2 = \text{Me}$

$\text{R}_1 = \text{CONHCH}_2\text{COOH and -COOEt}^{96,97}$

$\text{R}_2 = \text{Cl}$

$\text{R}_1 = \text{CONHCH(COOH)CH(COOH)NHAc-DL}^{98}$

$\text{R}_2 = \text{Me}$

SCHEME XII

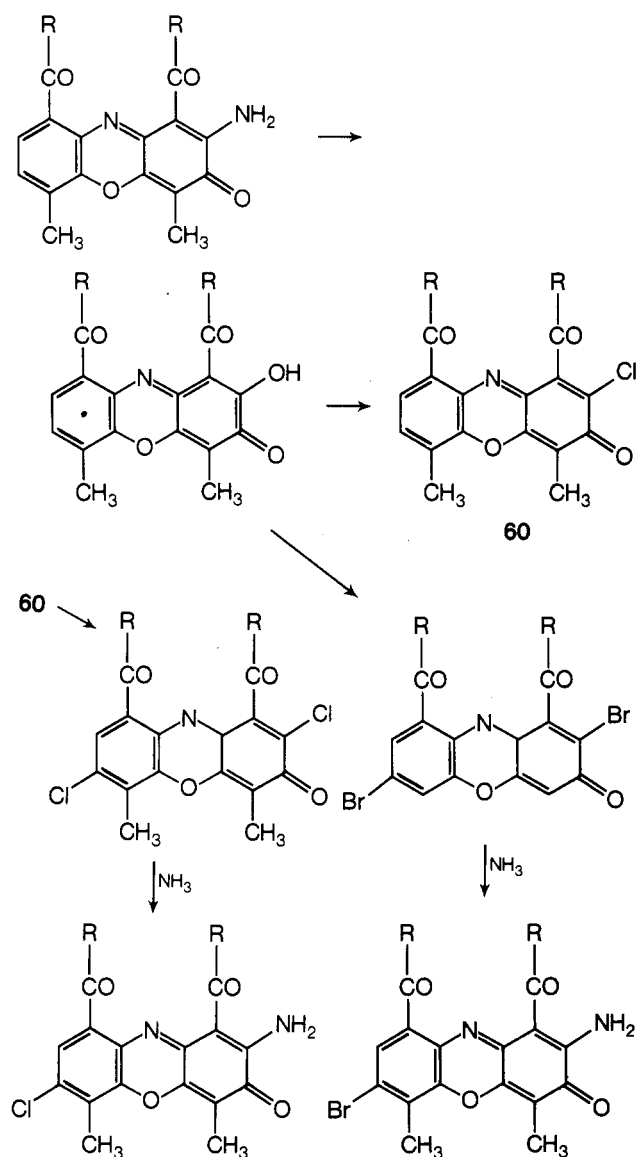

3,10-dihydro actinomycin condenses with ketones. After hydrogenation and reoxidation, N-substituted actinomycins (C₂) (59) are secured.

Introduction of Cl and Br in the 7-position was achieved via the 2-deamino-2-chloroactinomycin (C₃) (60)^{79,88} (Scheme XII).

The 4,6-dedimethyl-4,6-dibromo analog of actinomycin C₁ (D) was synthesized by Seela⁸⁹ by the now classical method: benzoylthreonine + tetrapeptide, oxidative coupling, and dilactonization.

A number of 4,6-dichloro-4,6-dedimethyl analogs (61) were synthesized with *p*-quinone or K₃Fe(CN)₆ from the suitably substituted monomers.

Actinocin analogs in which the 4- and 6-methyl groups

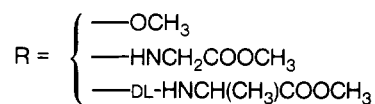
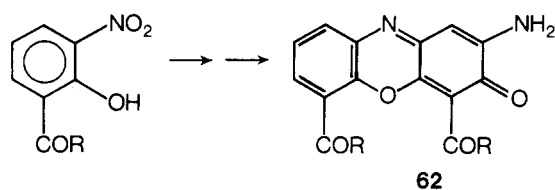

are replaced by substituted acyl groups (62) were obtained from appropriately substituted monomers by the usual method.⁹⁹

III. X-Ray Studies

Because of the initial ambiguity between a bis-pentapeptide lactone or a decapeptide dilactone⁶⁵ and because of the discovery by Kersten¹⁰² that the biological action of actinomycin was due to its complexing with DNA, it became important to study the steric arrangement of the peptide lactone rings. The study was first undertaken in Göttingen³⁶ by X-ray analysis of several polymorphs of actinomycin C₃. It was argued that any decapeptide-dilactone chromophore could be ruled out because of its inability to fulfill the requirements of the hexagonal (rhombohedral) space groups determined. It was also suggested that the bis-pentapeptide structure would lend itself far more easily to sandwiching between DNA base pairs than the far more bulky decapeptide dilactone arrangements.

Perutz disagreed with the former conclusion, claiming that a choice between the two alternate structures cannot be made from considerations of space group symmetry alone. Actinomycin C₃ appears to possess a pseudotwofold axis of symmetry in the plane of the phenoxazine ring.¹⁰³

The decapeptide structure was again tentatively preferred on the basis of additional X-ray diffraction data.¹⁰⁴

IV. Behavior of Actinomycin in Solution

A. Dimerization

Müller initiated the investigation of the behavior of actinomycin (C₃) in solutions.¹⁰⁵ Molecular weight determinations by sedimentation equilibrium showed that actinomycin aggregates in aqueous solution. Between concentrations of 10⁻⁵ and 10⁻³ M dimers predominate, above 10⁻³ M oligomers. In organic solvents only monomers were found. An increase in temperature causes an increase of aggregation. The inverse solubility gradient (20 g/100 ml at 1° and 0.08 g/100 ml at 20°) is ascribed to this. Proposed models require a stabilization by the hydrophobic interaction of the amino acid alkyl residues. This was confirmed by a polarographic determination of the diffusion coefficients which depend on the viscosity of water-methanol mixtures.¹⁰⁶

Actinomycin shows a remarkable increase in solubility with temperature decrease. The solution entropy change is large and negative at low temperatures (-37 eu/mol at 61.0°).¹⁰⁷ If corrections were made for the entropy of fusion and mixing, the remaining entropy of solvation would be found to be even larger. The solution ΔH° goes from -37 kcal/mol at 11.7° to -6 kcal/mol at 61.0°. It is likely that the controlling interaction is that between actinomycin and the solvent.

B. CD/ORD Studies

Electronic, ORD, and CD spectra of actinomycin have been measured in water and various less polar solvents.¹⁰⁸ While the $\lambda_{\max}^{\text{H}_2\text{O}}$ lies at 441 nm, the spectrum in methanol, ethyl acetate, and benzene shows two peaks at about 425 and 445 nm. The ORD in water shows weak minima at about 400 and 460 nm, while the spectrum in the less polar solvents exhibits one intense minimum at 410 nm. The optical activity in the visible does not seem to be associated with the λ_{\max} at 441 nm but with an absorption band at 375 nm. It was concluded

that the visible absorption spectrum of actinomycin in water is the sum of several bands representing different electronic transitions. This situation is the same in the apolar solvents, but one can notice that the splitting of the absorption peak may correspond to two vibrational carbonyl bands. Two explanations may be given for the difference between the spectrum in water and in organic solvents: (i) interaction between solvent molecules and chromophore, and (ii) deformation of actinomycin, possibly through the polypeptide chains, because of differences in dielectric constants of the solvents.

Crothers reinvestigated the solution behavior of actinomycin C₃ by equilibrium sedimentation and by optical rotatory dispersion.¹⁰⁹ The results from equilibrium centrifugation indicate that, as the concentration approaches zero, monomers ($M = 1283$) predominate, but with increasing concentration, M_{app} rises to a plateau near 2566, reached at about 2 mg/ml at 20°. A simple dimerization equilibrium is consistent with their observations with K values of $3.6 \times 10^3 M^{-1}$ at 5° and $9.0 \times 10^2 M^{-1}$ at 20°. From this the heat and entropy of dimerization are estimated: $\Delta H^\circ_{\text{dimer}} = -15$ kcal/mol, and $\Delta S^\circ_{\text{dimer}} = -38$ eu/mol.

The ORD curve shows negative Cotton effects centered at 449 nm, induced by the asymmetric pentapeptide rings, near the chromophore absorptions at 425 and 441 nm, and at 376 nm near which wavelength there are no strong absorption bands. The ultraviolet negative Cotton effects centered at 269 and 213 nm represent resultant dispersion related to the optically active amino acid and peptide bond transitions as well as to the induced symmetry in uv transitions of the phenoxazine system. The Cotton effects at 269 and 449 nm increase with rising concentration until a plateau is reached, for which dimerization is responsible. At constant concentration the amplitude of the Cotton effect at 376-383 and 269-272 nm varies with solvent surface tension. Thus, solvent-dependent conformational changes, probably intramolecular ordering of the peptide rings, can be distinguished from dimerization which produces a Cotton effect at 449 nm.

Crothers ascribes the interactions, which give the dimer particular stability in water, to the hydrophobic class, an interpretation strengthened by the presence of several nonpolar amino acids in the molecule. The large negative heat of dimerization can be explained at least in part by assuming that during dimerization two cavities in the solvent accommodating two solute molecules merge to one, releasing heat due to the energetic distribution to the surface free energy (*vide infra*). The correlation of ORD with solvent surface tension supports this view.

CD studies show an inversion of sign of the Cotton effects in going from acetonitrile or chloroform to hexafluoroacetone hydrate.¹¹⁰ The effect is ascribed to two conformations imparting opposite chirality to the molecule: the twin peptide rings are face to face and perpendicular to the chromophore. In one case the C₁ carbonyl is above and the C₉ carbonyl below the chromophore plane; in the other case the situation is reversed. The CD spectrum in trifluoroethanol can be explained on the basis of a 70/30% mixture of the two isomers or by the existence of two opposite atropisomers in the same molecule, giving rise to a local "quasi" mesoform.

The inversion of the CD spectrum was further tested with other hydroxylic solvents, among which was chloral hydrate, a *gem*-diol.¹¹¹ Only the latter produced an inversion like hexafluoroacetone, also a *gem*-diol. It is now proposed that actinomycin interacts with *gem*-diols by exchange of the two intercycle NH-CO_{va1} hydrogen

TABLE V. Actinomycin D Chemical Shifts

Proton	CDCl ₃		δ				
	δ^a	<i>J</i>	Benzene	Acetone	Pyridine	Dimethylformamide	D ₂ O ^b
NHC=O D-Val	1.91	5.7	1.14	1.74	1.25	1.79	
NHC=O D-Val	2.06	6.0	1.37	1.82	1.35	1.79	
NHC=O Thr (1)	2.18	6.2	1.84	2.18	1.51	1.90	
NHC=O Thr (2)	2.80	6.8	2.25	2.50	1.74	2.06	
ArNH ₂	2.6-2.7			~2.5	1.78	2.60	
ArC ₃ H	2.36	7.8	2.33	2.41	2.22	2.53	2.49
ArC ₇ H	2.63	7.8	3.17	2.57	2.70	2.53	2.49
α -CH-MeVal	3.97	~7.5	~3.64	3.81	3.31	3.74	3.83
α -CH-MeVal	4.02	~7.5	~3.66	3.85	3.39	3.74	3.83
β -CH-Thr	4.79	2.0-2.5 ($\beta\alpha$)	4.28	4.77	4.26	4.80	
β -CH-Thr	4.85	6.0 ($\beta\gamma$)	4.28	4.77	4.26	4.80	
α -CH-Thr (1)	5.38	~6.5 (α -NH)	4.94	5.29	4.83	5.29	
α -CH-Thr (2)	5.49	2.0-2.5 ($\alpha\beta$)	4.94	5.35	4.83	5.29	
Sar (1)	5.21	17.8	5.51	5.33	5.13	5.40	
	6.37		7.08	6.07	6.12	5.88	
	5.28		5.55	5.33	5.13	5.40	
Sar (2)	6.37	17.8	7.08	6.07	6.12	5.88	
α -CH-Pro	~6.0	Ind ^c	~5.7-6.1	~6.0	5.6-5.7	~5.9-6.0	
α -CH-Pro	~6.1	Ind ^c	~5.7-6.1	~6.47	5.6-5.7	~5.9-6.0	
α -CH-D-Val	6.38	Ind ^c	~6.0	~6.32	5.8-5.9	6.14	
α -CH-D-Val	6.38	Ind ^c	~6.0	~6.32	5.8-5.9	6.14?	
CH ₂ N-Pro (2 H)	6.25-6.30		~6.0	~6.32	5.25-5.40	6.3-6.4	
NCH ₃	7.06 (3 H)		7.23	7.11 (3)	7.24 (3 H)	7.06 (6 H)	6.98 (6 H)
			7.25	7.14 (3)	7.20 (3 H)	7.08 (6 H)	
NCH ₃	7.11 (9 H)		7.80	7.18 (6)	7.00 (6 H)	7.17 (6 H)	7.09 (6 H)
			7.85				
CH ₂ N-Pro (2 H)	7.33 (m)		7.2-7.5	7.1-7.3?	6.88	6.92	
			7.56 (<i>J</i> gem 9.0)		7.2	~7.2-7.3	
β -CH-MeVal	7.25-7.40		7.3-7.4	7.34-7.44	7.15-7.25	~7.48	
6-CH ₃	7.44		7.91	7.48	7.65	7.46	7.44
4-CH ₃	7.76		8.13	7.96	7.85	7.83	7.84
β -CH-D-Val	~7.8		7.5-7.6	7.79-7.89	~7.35-7.45	~7.90	
3 + 4-CH ₂ -Pro	7.8-7.9		7.8-8.2	~7.9	7.7-8.0	~7.85	
4-CH ₂ (2 H)Pro	8.15 ^d		~8.2 ^d	8.2 ^d	7.7-8.0	8.17 ^d	
Thr-CH ₃	8.73	6.0	8.35	8.70	8.38	8.71	8.64
				8.72		8.73	
D-Val-CH ₃	8.87	6.5	8.49	8.86	8.48	8.88	8.91 ^d
D-Val-CH ₃	9.09	6.5	8.52	9.11	8.74	9.14	9.13 ^d
MeVal-CH ₃	9.04		9.04	9.04	8.94	9.03	9.02 ^d
			9.08				
			9.49				
MeVal-CH ₃	9.24		9.50	9.24	9.26	9.24	9.19 ^d

^a τ scale. ^b Relative to internal dimethylsilapentanesulfonic acid. ^c Indeterminate. ^d Tentative.

bonds for hydrogen bonds with the *gem*-diol by rotation of the cyclopentapeptide rings by 180° with resulting inver-

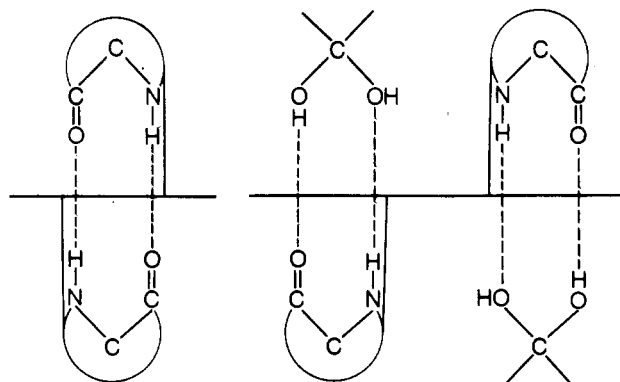

sion of chirality. In support of this model, the corresponding actinocinylibis(Thr-methyl ester) gave no inversion in hexafluoroacetone.

The actinomycin chromophore is isolated from the

nearest asymmetric carbon in the peptide chains, and the question arises whether this chromophore is optically active.¹¹² ORD and CD spectra of actinomycin were compared with those of the mono- and diactomycinic acid (one and two lactones opened), in water, ethanol, and benzene. The optical activity of the major absorption band (450-440 nm) is weak. However, a strong optically active band is present at ~380 nm. Both bands require the presence of both lactone rings. Two explanations are given: (i) through interaction the intact lactone rings assume one rigid conformation imparting dissymmetry to the molecule; upon scission of the lactone rings the free movement of the chains cancels dissymmetry; or (ii) as a result of steric interaction between the two lactone rings planarity of the chromophore is distorted as to become dissymmetric. The strain is released upon opening of the lactone rings.

C. Nmr Studies

Arison and Hoogsteen completely assigned 100- and 220-MHz nmr spectra of actinomycin to establish specific

TABLE VI. Conformational Properties Deduced from Coupling Constants

Residue	Type	Magnitude	Conformation
Thr	HN-C α H	6.3	Trans
Thr	HN-C α H	5.7	Trans
Val	HN-C α H	5.7	Trans
Val	HN-C α H	5.7	Trans
Thr (α - β)	HC α -C β H	1.5 [4.8] ^a	Gauche
Thr (α - β)	HC α -C β H	1.5 [4.8]	Gauche
Val (α - β)	HC α -C β H	0.5 [4.4]	Gauche
Val (α - β)	HC α -C β H	0.5 [4.4]	Gauche
MeVal (α - β)	HC α -C β H	9.2 [7.2]	Trans
MeVal (α - β)	HC α -C β H	9.2 [7.2]	Trans

^a Values in square brackets refer to couplings in the free amino acids.

Table VII. The 100-MHz Nmr Spectrum of 63 in CDCl₃-D₂O

		δ , ppm (Hz)
NH	Thr	9.70 (9.5)
NH	Val	6.49 (8.2)
H-6		7.47 (8.0)
H-5		7.39 (8.0)
H-3	Thr	5.81 (6.3/1.0)
H-2	Thr	4.90 (9.5/1.0)
H-2a	Sar	3.05 (14.0)
H-2b	Sar	4.75 (14.0)
H-2	Pro	4.80-4.90
H-2	MeVal	4.74 (11.6)
H-2	Val	4.39 (8.2/7.0)
H-5a	Pro	4.10
H-5b	Pro	3.55
CH ₃ O		3.88
N-CH ₃	Sar	3.39
N-CH ₃	MeVal	3.22
4-CH ₃		2.37 (<0.3)
H-3	MeVal	2.0-2.4
H-3	Val	1.8-2.2
H-3/4	Pro	1.8-2.4
CH ₃	Thr	1.27 (6.3)
(CH ₃) ₂	Val	0.97 (6.3)
		0.97 (6.3)
(CH ₃) ₂	MeVal	0.91 (6.6)
		0.80 (6.6)

geometric relationships in the pentapeptide rings.¹¹⁵ Solvent effects and the behavior of active hydrogens shown in Table V led to the following conclusions: (i) the β -NH_{Thr} forms a hydrogen bond with the C₉=O, likewise between the C₁-CO and C₂-CH₂ (the α -NH_{Thr} is not involved in hydrogen bonding); (ii) the negative centers of Thr and Val are located near the molecular periphery; (iii) the MeVal- α -CH and one of the Sar methylene protons are close to and coplanar with a carbonyl group of either Pro or Sar; (iv) the Pro methylenes are close to the Pro and Val carbonyls, especially the NCH₂Pro; and (v) the two pentapeptides are parallel to each other and perpendicular to the phenoxazine, anchored by the hydrogen-bonded β -Thr-NH (see (i)).

Danyluk observed the nmr spectrum of actinomycin and its solvent and temperature effects.^{114,116,117} In all four Thr and Val residues the HC α -NH protons favor trans conformations. Furthermore, a gauche vicinal relationship is indicated for the HC α -C β H protons of the Thr side chains. Gauche and/or trans conformations are favored for the HC α -C β H protons of Val and MeVal. These relationships are shown in Table VI. There is no intermolecular solute-solute hydrogen bonding (N-H) or stacking (actinocin) in nonaqueous solvents. However, the NH

TABLE VIII. The 220-MHz Nmr Shifts of Actinomycin in D₂O^a

Proton type	Shift (ppm ^c \pm 0.01 ppm)	Proton type	Shift (ppm ^c \pm 0.01 ppm)
MeVal CH ₃ (1) ^b	0.82	MeVal N-CH ₂ (1) ^b	3.01
Val CH ₃ (1) ^b	0.85	MeVal N-CH ₂ (2) ^b	3.05
MeVal CH ₃ (2) ^b	0.99	Val C α H	3.35
Val CH ₃ (2) ^b	1.10	MeVal C α H	3.40
Thr CH ₃	1.38	Sar CH _X	3.70
Actinocinyl group CH ₃ (B)	1.69	Sar CH _A	3.77
Pro CH ₂	2.05	Thr C α H	4.24
Val C β H	2.15	Thr C β H	6.24
Actinocinyl group CH ₂ (A)	2.49	Pro C α H (1) ^b	6.35
MeVal C β H	2.55	Pro C α H (2) ^b	6.37
Sar N-CH ₃	2.90	Actinocinyl group HA, HB	7.47

^a Concentration of actinomycin = 3.90×10^{-3} M; $\mu = 0.40$ M. ^b The numbers refer to nonequivalent groups. ^c Shifts are in ppm relative to internal sodium 3-trimethylsilylpropionate-2,2,3,3-d₄.

and NH₂ groups are involved in intra- and intermolecular (solvent-solute) interactions in the proton acceptor solvent CDCl₃. The (NH)_{Val} protons are more strongly intramolecular bonded than the (NH)_{Thr} protons. The possibility of intra-ring (NH)_{Val} to C=O_{Sar} bonding is considered. There is a pronounced conformational rigidity of the cyclic peptides in nonaqueous solvents, a stabilizing effect undoubtedly due to intra- or inter-ring H bonds. There is indication that the proline rings are in very close proximity to the Sar methyl groups on the basis of these studies and Overhauser experiments by Danyluk. At room temperature the Thr-NH-C=O group must be out of the plane of the phenoxazinone.

Danyluk arrived at a conformational model with the following features.¹¹⁷ The backbones of each peptide ring lie roughly in one plane. The two pentapeptide planes are parallel to each other and normal to that of the actinocin ring system. The two Sar-N-CH₃ groups face the interior region between the peptide rings and are, therefore, screened from solvent molecules on the inside, while their outside is protected by the Pro rings.

Lackner investigated the secondary and tertiary structure with regard to the peptide ring and the dihedral angle around the actinocinyl-C₁(C₉)-C=O- and the Thr-N-C₂- bond.¹¹⁸ Rotational isomers may arise from variation of angles ϕ and ϕ' .

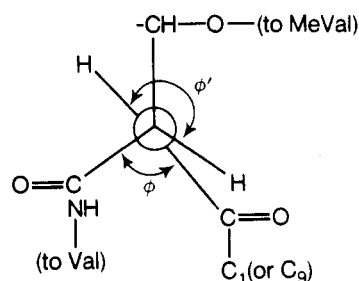

The 100-MHz spectrum of 63 is tabulated in Table VII.⁶³ It is in agreement with a conformation (64) which is also arrived at by models, assuming trans amide bonds and a long NH_{Val}...O=C_{Sar} hydrogen bond. The dihedral angle around bond c is 120°, around NH-C₂H_{Thr} 180°, around bond p 90°, around C₂H-C₃H_{MeVal} 180°, and around NCH₃-CH_{b,Sar} 180°.

It is interesting to note that this unicyclic monomeric unit dimerizes ($M_{osm} = 1400$) in benzene, observable

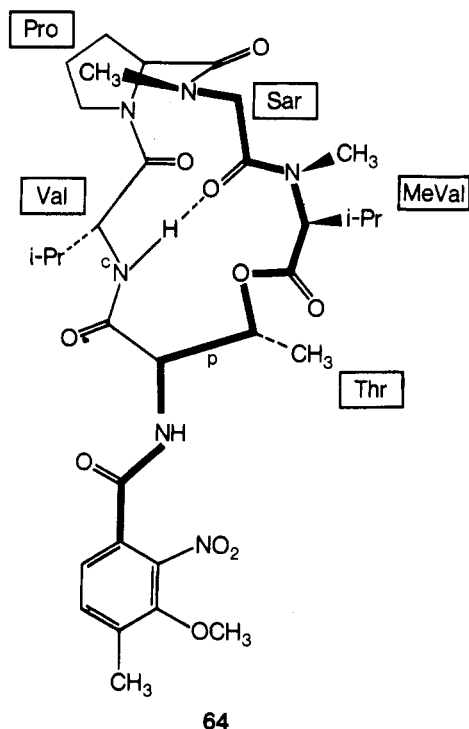
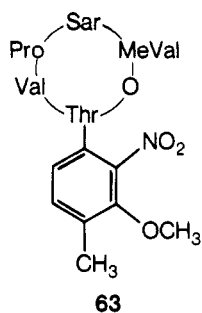

through nmr side bands. Presumably two parallel units are placed face to back.

For the study of actinomycin itself, Lackner used synthetic products which were selectively deuterated in the α - or β -peptide ring.⁶² Only then can nmr signals of corresponding groups be assigned to the α or β ring.¹¹⁹

A picture of the secondary and tertiary structures emerges: (i) the two rings have the same conformation; (ii) their conformation corresponds to that of the monomeric unit;⁶³ and (iii) the twin rings are situated face to face, whereby the $N-CH_3(Sar)$ groups lie inside. Coplanar arrangement of rings and chromophore are excluded on steric and nmr spectroscopic grounds; and (iv) the angles ϕ_α and ϕ_β ¹¹⁸ are believed to be equal; however, they cannot be 0 or 180°.

The existence of a dimer at $>10^{-4}$ M was established with no detectable formation of higher aggregates, even at concentrations approaching saturation, but the orientation of the two actinomycin molecules leaves still open an interaction between the pentapeptide rings or involvement of the actinocinyl chromophore. The aggregation of actinomycin D was once more investigated by nmr.¹¹³ A 60-MHz¹¹⁴ and 100-MHz¹¹⁵ assignment were known. Thus, a distinction between peptide or chromophore involvement is possible based on dimerization-induced proton shifts in key groups. Actinomycin D was measured at 220 MHz at various concentrations, pH, and temperature. Only dimers were confirmed involving vertical stacking interaction of the actinocinyl group with one chromophore inverted with respect to the second.

The measurements were done in benzene- d_6 , binary $C_6D_6-CD_3OD$ mixtures, CD_3COD , binary CD_3COD-D_2O mixtures, and D_2O , employing deuterium exchange and spin-decoupling techniques. Variation of solvent produces characteristic shift changes. The chemical shifts in D_2O are given in Table VIII.

The spectrum was then studied at different concentrations at 4 and 18° in D_2O and at different pH values. At increasing concentration the shifts of the pentapeptide ring protons remain unchanged in marked contrast to the two aromatic actinocinyl hydrogens and the two actinocinyl methyls, which shift upfield. Simultaneous line broadening is observed indicating decreased relaxation times, as would occur in an aggregate. The actinocinyl groups also show temperature and slight pH dependence. Dimerization equilibrium constants of $2.70 \times 10^3 M^{-1}$ at 4° and $1.40 \times 10^3 M^{-1}$ at 18°, both at pD 7.2, were obtained. Danyluk interprets the negative enthalpy change for the dimerization as an aggregation process involving stacking interactions between π -electron systems. He arrives at a model (65) after considering vari-

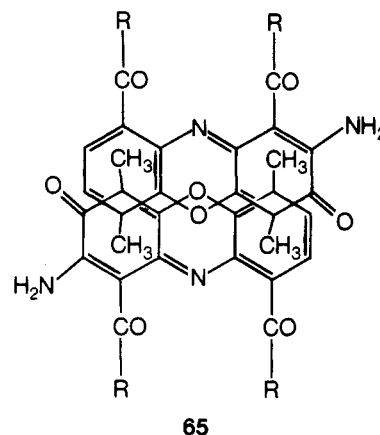

ous arguments, notably the behavior of the actinocinyl methyl shifts in connection with an estimated shielding anisotropy of the actinocinyl chromophore.

In another 100-MHz nmr study¹²⁰ the corresponding protons in the α - and β -chain are observed to be magnetically nonequivalent. The NH_{Val} protons are strongly hydrogen bonded, and there may be a weak hydrogen bond at the NH_{Thr} . All $N-CH_3$ protons are trans with respect to the peptide bond. The strong hydrogen bond must be intramolecular between rings from NH_{Val} to CO_{MeVal} (in disagreement with Danyluk's and Lackner's findings). The dihedral angle in $C_\alpha H-C_\beta H_{Thr}$ is about 60°.

Two types of structures have been derived^{121,122} by studying sterically allowed conformations of the pentapeptide lactones on the basis of energy calculations taking into account nmr, infrared, CD data, preliminary X-ray data, and the geometrical conditions for ring closure. One corresponds to a structure with two intracyclic $NH_{Val} \cdots CO-C_{1(9)}$ hydrogen bonds, and one corresponds to a structure proposed earlier^{63,104} and containing intracyclic $NH_{Val} \cdots CO_{Sar}$ hydrogen bonds. The latter structure suffers from lack of rigidity, a factor required by the relative invariance of the CD and nmr spectra upon changing temperature or solvents. Another set of two structures, similar to the structure proposed by Sobell,^{24,123-125} has the two rings out of plane and on opposite sides of the phenoxazone plane and contains two inter-cyclic $NH_{Val} \cdots CO_{Val}$ hydrogen bonds. The two structures are very similar; one has the Sar peptide bond cis, the other trans. Unlike Sobell's model the angles between the $CO-NH_{Thr}$ plane and the phenoxazone plane

are not equal (38 and 118° for the α - and β -chain, respectively), explaining the difference in NH_{Thr} nmr shifts and the abnormal chemical shift of one $\text{CH}_2\text{N}_{\text{Pro}}$ group, presumably due to its close contact with the C_1 -CO group.

V. Complexes with Constituents of Nucleic Acids

The complex binding between actinomycin and DNA has been known in the late 1950's. Since it has become clear that the binding was specifically to the bases, a number of binding studies with bases and nucleosides was undertaken. The complex is detected by a hypochromic (up to ~50%) bathochromic (+10 nm) shift of the visible absorption maximum at 442 nm. Kersten¹²⁶ measured the effect expressed as a difference between maximum and minimum of the difference spectrum (complex minus actinomycin), deriving a binding ability sequence: deoxyguanosine \gg guanine > adenine > adenosine \approx deoxyadenosine > AMP, ADP, ATP > inosine \approx xanthosine.

The tendency of purines and their nucleosides or nucleotides to form molecular associations, possibly of the charge-transfer complex type, with electron acceptors is not uncommon. Pullman¹²⁷ calculated the energy coefficient of the highest occupied molecular orbital of a number of purines. The smaller this coefficient, the lower the first π ionization potential and the greater therefore their electron donor ability. He arrives at a sequence, resembling that deduced from data of Reich,¹²⁸ viz., thioguanine > guanine > 2,6-diaminopurine \approx 6-dimethylaminopurine > 6-methylaminopurine \approx aminopyrazolopyrimidine > adenine \approx 2-fluoroadenine > 2-aminopurine \approx benzimidazole > 6-methylpurine > purine. The most probable agreement in the complex is of the stacking type, with plane-to-plane interaction.

The spectral properties of a number of purine-actinomycin mixtures were investigated.¹²⁸ It is shown that the structural features in DNA which account for its complex forming capacity cannot be deduced from a study of the model reaction with purines (see section VI), because hypochromic shifts with the latter are 10–20 times weaker and no single structural feature of the purine ring seems indispensable for the reaction with actinomycin, in marked contrast to the reaction of nucleic acids where only the guanine in DNA can react with actinomycin. The same conclusion was reached by Gellert,¹⁰⁷ who compared the free energy, enthalpy, and entropy of binding of actinomycin to DNA with that of deoxyguanosine. The latter is characterized by a relatively small association constant ($\sim 10^3$). The entropy change is unfavorable for interaction (-15.1 eu/mol), but ΔH is negative (-9.1 kcal/mol). On the other hand, DNA binds actinomycin $\sim 1000\times$ stronger, the reaction is accompanied by a negligible enthalpy change, and the driving force for the reaction arises from a large entropy increase ($+31$ eu/mol).

However, it should be pointed out that a crystalline actinomycin-dG₂ complex, studied later, could be used advantageously to arrive at a model for actinomycin-DNA interaction¹⁵⁸ (see section VII).

From molecular weight determinations by equilibrium sedimentation and stoichiometric and kinetic (temperature-jump) measurements,¹²⁹ it was concluded that the actinomycin C₃-deoxyguanosine complex consists of two molecules of each partner and is formed in the reaction $(\text{actinomycin})_2 + 2\text{dG} = (\text{actinomycin})_2(\text{dG})_2$. The two binding sites on the actinomycin dimer are equivalent

and independent of each other. Association constants of 22 natural and synthetic actinomycins were found in the range 10^2 to 10^3 , with $\Delta H^\circ = 8.3$ kcal/mol and $\Delta S^\circ = 13$ cal/(mol deg) for actinomycin C₃. Because of the high rate constant for the complex formation (1.5×10^8 l./mol sec) for actinomycin C₃, the reaction must be diffusion limited; i.e., the partners react at each sterically favorable collision.

Spectrophotometrically determined association constants for 1:1 complexes of actinomycin D with a variety of purines and purine derivatives vary in the 10^2 to 10^3 range. Guanosine binds stronger than adenosine, and deoxyribose derivatives bind stronger than ribose derivatives.¹³⁰

Crothers and Ratner¹³¹ measured thermodynamic constants for the formation of the actinomycin-deoxyguanosine complex in water-methanol mixtures with the specific purpose of distinguishing between the surface tension approach to solvophobic effects¹⁰⁹ and the standard view of hydrophobic effects as arising from an ordering of solvent molecules around the solute. The latter view is favored because the complex is destabilized ($\Delta G^\circ = -4.44$ kcal/mol at 100% H₂O and -3.50 kcal/mol at 40% methanol) in the presence of increasing methanol concentration, due to an increasingly negative entropy of complex formation ($\Delta S^\circ = 19.8$ cal/(mol deg) at 100% H₂O and -33.2 cal/(mol deg) at 40% methanol).

Homer¹³² measured the CD spectrum of actinomycin with a 100-fold excess of dG-5'-phosphate, conditions under which Müller's 2:2 complex was formed.¹²⁹ It exhibits a positive and negative band, which would be expected for a dimer with the chromophores close to one another. The geometry involved is quite different from that of the complex of actinomycin with DNA.¹³²

So far two types of configuration have been proposed for the 1:1 purine-actinomycin complexes: (i) the purine, e.g., guanine, is assumed to hydrogen-bond with the quinoid portion of actinomycin to form a complex in which the aromatic rings of both molecules are coplanar¹³³ (66);

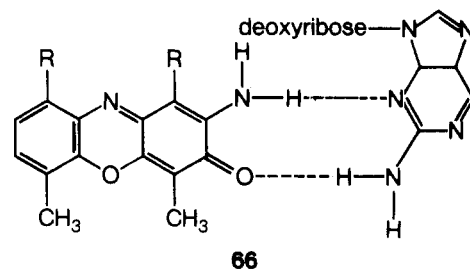

and (ii) the purine ring is assumed to be stacked over the actinomycin ring analogous to stacking of purine derivatives themselves (67). Initial nmr evidence for an actinomycin

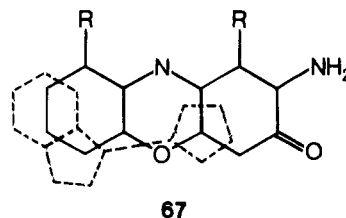

-dG₂ complex was provided by Arison and Hoogsteen. They arrived at a stacking-type interaction for this complex.¹¹⁵ Further attempts to confirm the correct structure by nmr were made by Danyluk.¹¹⁷ Type (i) would lead to downfield shifts while (ii) would produce the opposite effect. From the fact that the two actinomycin ring hydrogens and the benzenoid methyl are shifted upfield by purine

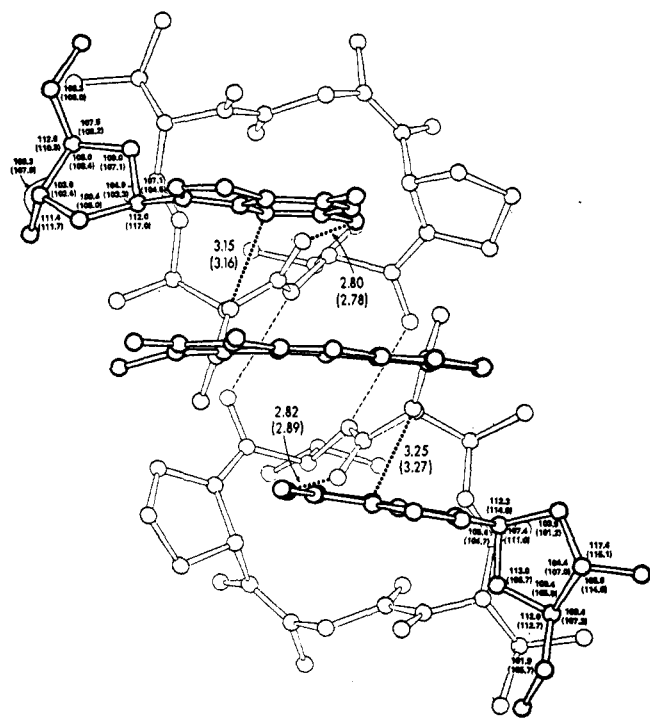

Figure 4. ORTEP illustration of the actinomycin-2dG complex, viewed down its quasi dyad axis. Dotted lines indicate hydrogen bonds connecting the pentapeptide chains with each other and with the deoxyguanosine molecules. Bond distances and angles obtained from the heavy-atom analysis are shown in parentheses; those shown without parentheses have been obtained from the light-atom analysis (from Jain and Sobell,¹²⁵ with permission).

derivatives (pyrimidines produced no shift at all), it can be concluded that the purine rings must be stacked over the actinocin system. With dG and dG-5'-PO₄ the quinoid methyl was shifted downfield. The latter situation points to a structure in which the guanine ring is predominantly located over the benzenoid ring, while the deoxyribose (phosphate) is situated near the quinoid ring.

The weak actinomycin-deoxyguanosine complex can also clearly be distinguished from the much firmer DNA complex by ORD.¹⁰⁸ The ORD curves of the two complexes are different both in amplitude and shape. Presumably this is due to the greater steric freedom of the former complex, which imposes much less constraint to the conformation of the bound actinomycin molecule.

A major breakthrough in the elucidation of the structure of an actinomycin-dG complex was achieved by Sobell¹²³⁻¹²⁵ by X-ray diffraction. It is clear that X-ray diffraction determination of a structure in the solid state would be an acceptable substitute for the determination of its conformation in solution since it is unlikely that the conformation will be much different in the liquid state. Yet, the difference between the solid and liquid state must be kept in mind. Such an X-ray analysis has become possible because of the successful crystallization of a 1:2 actinomycin D-dG complex. Work proceeded on two crystalline modifications, one of which has been reported in detail.¹²⁵ X-Ray diffraction data were collected from a 7-bromoactinomycin C₁-2dG complex with almost identical cell parameters as the actinomycin D-2dG complex. Analysis shows that actinomycin has quasi-C₂ symmetry with the axis lying roughly along a line connecting O and N in the center ring of the phenoxazinone. Exact C₂ symmetry is not achieved because of the C₂-amino group and the C₃=O group. Both polypeptide rings obey this twofold symmetry: the "benzenoid"-attached α -chain

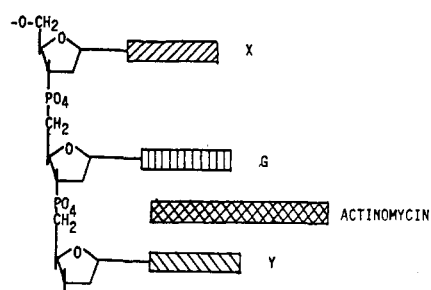

Figure 5. Interaction of actinomycin with G-containing di- or polynucleotides (after Schara and Müller¹³⁴).

lies above the plane of the chromophore, and the "quinoid"-attached β -chain, having identical conformation, lies below this plane. The peptide linkages are Thr-Val, trans; Val-Pro, cis; Pro-Sar, cis; Sar-MeVal, trans; and Thr-carboxamide carbonyl oxygen and C₁(C₉)-C=O, trans. A strong hydrogen bond exists between neighboring cyclic pentapeptide chains connecting NH_{Val}(α) to C=O_{Val}(β) and NH_{Val}(β) to C=O_{Val}(α).

The two dG units are situated symmetrically with respect to actinomycin, preserving the quasi-C₂ symmetry; they are stacked on alternate sides of the phenoxazine system. A strong hydrogen bond connects one guanine 2-amino group with the C=O_{Thr}(α) and one with the C=O_{Thr}(β). There is a weaker hydrogen bond between the guanine N₃'s and the corresponding NH_{Thr}(α or β) (Figure 4).

The 1:2 stoichiometry of the complex is a direct consequence of the quasi-twofold symmetry of actinomycin and has important implications for a model for the interaction of actinomycin with DNA (see section VI).

The stoichiometry in the actinomycin-dG₂ crystal, however, is contrasted by the $n:n$ compositions found in aqueous solutions.^{107,109,130} Therefore, Müller investigated the interaction of actinomycin C₃ with several dinucleotides and a tetranucleotide.¹³⁴ The sequence specificity was studied by measuring the dissociation constants of the complexes by spectral titrations. G-Containing dinucleotides form complexes of roughly ten times higher stability than G-free dinucleotides. The former group may be subdivided into three classes: (i) d(pX-G) which bind actinomycins with similar affinity as the dGMP, $K \approx 2 \times 10^3$; (ii) d(pG-X) which bind actinomycins less strongly than dGMP, $K \approx 7 \times 10^2$; and (iii) d(pG-C) which binds actinomycins in a 1:2 complex corresponding to Sobell's structure,¹²³⁻¹²⁵ $K \approx 1.4 \times 10^7$. Further support for this 1:2 complex was obtained through molecular weight determination by sedimentation equilibrium. The tetramer d(pC-T-A-G), which behaved like type (i), and d(pC-G) yielded 2:2 complexes with actinomycin.

These results are in agreement with the model in which the binding of the actinomycin chromophore to 5'-d(GMP) takes place at the 3'-end (Figure 5). Thus, in a di- or polynucleotide the nucleotide at the 5'-end of dG (X) feels no influence from the actinomycin d(GMP) interaction. However, a nucleotide on the 3'-side (Y) clearly influences this interaction. When Y = A or T, the complex stability is lowered, but if Y = C, a 1:2 complex is formed.

The association constant for the actinomycin-d(pG-C)₂ complex formation can be split into a $K_1 \approx 10^3$ and a $K_2 \approx 1.5 \times 10^4$. The relative high value of K_2 must be due to the complexing of two GC base pairs, between which an actinomycin chromophore is intercalated. The stabilization of the complex is a consequence of the coopera-

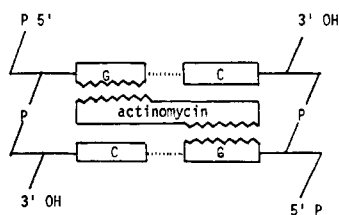

Figure 6. The 1:2 actinomycin:[d(pG-C)]₂ complex (after Schara and Müller¹³⁴).

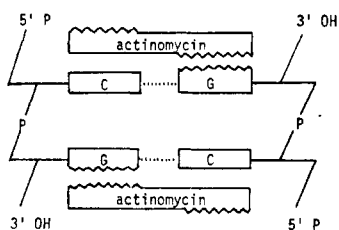

Figure 7. The 2:2 actinomycin:(pG-C) complex (after Schara and Müller;¹³⁴ in view of Sobell's model¹⁵⁸ the complex as shown would be sterically impossible because the peptide portion of actinomycin covers three base pairs on either side of the phenoxazone ring system).

tivity between generated hydrogen bonds, electronic and hydrophobic forces.

The 1:2 actinomycin-d(pG-C)₂ complex and the 2:2 actinomycin-d(pC-G) complex are represented in Figures 6 and 7, respectively.

Figure 8 shows a schematic view of the 2:2 (actinomycin)₂-[d(pC-T-A-G)]₂ complex. It is of interest to note that the latter complex does not form higher aggregates in which additional double helix tetramers are joined with their 3'-terminal dG's to the already bound actinomycin chromophores. This problem is related to the apparent inability of actinomycin to form a 1:2 complex with d(GMP).

A similar study was carried out by Krugh.¹³⁵ Specifically, it could be shown that d(pGpC) interacts strongly with actinomycin in a cooperative fashion, indicating that actinomycin has a preference for GpC sequences of DNA as potential binding sites. The dinucleotides d-(pXpG) with X = C, T, and A resemble dG in their binding properties, the reaction being first order. However, dinucleotides of the type d(pGpX) (X ≠ C) bind less tightly, with first-order character. Stereochemically, this can be explained on the basis of the geometry found in the actinomycin-dG₂ complex but does not involve intercalation between the two bases of the dinucleotide. Similarly, the d-(pGpX) (X ≠ C) complexes use the same geometry and do intercalate, but complex formation with one dinucleotide prevents complexing with the second dinucleotide, because the bases are noncomplementary. The situation is unique in d-(pGpC), where the steric fit for intercalation between two complementary dinucleotides is perfect. The reaction proceeds cooperatively between one actinomycin and two d-(pGpC)'s.

In continuation of former nmr work,^{113,115,117} Krugh also studied actinomycin D-deoxymononucleotide¹³⁶ and -deoxydinucleotide¹³⁷ complexes by nmr (100 MHz) at various nucleotide:drug ratios in order to determine the stoichiometry and geometry of the complexes. The chemical shifts of the actinomycin D protons changed until the ratio [dGMP]/actinomycin > 2, providing evidence that a complex with two dGMP molecules is formed. The characteristic changes of the C₄-CH₃ and C₆-CH₃ proton shifts are in agreement with the following mechanism. Initially dGMP binds to the actinomycin dimer, which is

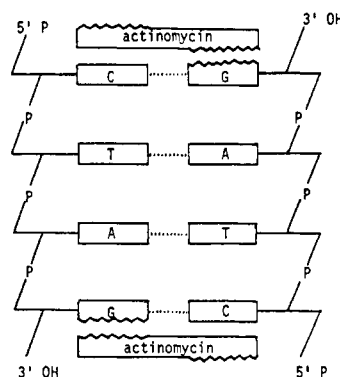

Figure 8. The 2:2 (actinomycin)₂-[d(pC-T-A-G)]₂ complex (after Schara and Müller;¹³⁴ in view of Sobell's model¹⁵⁸ the complex as shown is sterically impossible because the peptide portion of actinomycin covers three base pairs on either side of the phenoxazone ring system).

predominantly present at the concentration (0.02 M) necessary for nmr measurements. The dimer, which is clearly of the antistacking type (63), has two outer binding sites available. As the dGMP/actinomycin ratio increases, the actinomycin dimer is disrupted in a competition between actinomycin-(dGMP)₂ complex formation and actinomycin chromophore dimerization. The situation is similar for the actinomycin-(GMP)₂ complex, which possibly has a hydrogen bond between the 2'-OH of GMP and the C₃=O of actinomycin.

Titration of actinomycin D with 5'-TMP produced no changes in the chemical shifts, consistent with previous findings that TMP does not interact with actinomycin. Interaction with dAMP exists, presumably with similar geometry as in the complex with dGMP. The situation is less clear in the case of AMP, although binding clearly occurs. The studies further indicate a difference between the binding sites on the benzenoid ring and on the quinoid ring.

VI. Binding of Actinomycin to DNA

This topic has been reviewed frequently in recent years,¹⁷⁻²⁴ from a molecular biology point of view. The subject will therefore only briefly be dealt with in this review. While the cytostatic properties of actinomycin have been known since its discovery,¹³⁸ the reasons for this, viz. the complexing of actinomycin with DNA¹⁰² and the consequential inhibition of RNA synthesis,^{139,140} only became known in the early 1960's. The complex formation has been studied using spectrophotometric methods, buoyant density measurements, equilibrium dialysis, CD and ORD,^{103,132,147} melting temperature, and inhibition of DNA template controlled RNA synthesis. By much larger actinomycin concentrations DNA controlled DNA synthesis is also inhibited, but the mechanism seems to be a different one. While the former is a direct consequence of steric interference by the antibiotic, the latter seems to be a stabilization of DNA.¹²⁸ Actinomycin also interferes with reactions in which DNA is modified, such as methylation.¹⁴²

Actinomycin complexes with DNA but not with RNA. The association constant is about $5 \times 10^6 M^{-1}$. The DNA must be double-stranded helical and contain guanine residues.¹⁷ The number of nucleotide pairs per bound actinomycin molecule runs from 0 at 0% dG content to about 6 at 50% dG in poly-d(G-C),¹⁴³ with relative constance of the number of binding sites in the middle range,¹⁰⁷ possibly suggesting the involvement of more than one base pair. In DNA with adjacent dG's less than half of these sites are available for binding.¹⁴⁴⁻¹⁴⁶

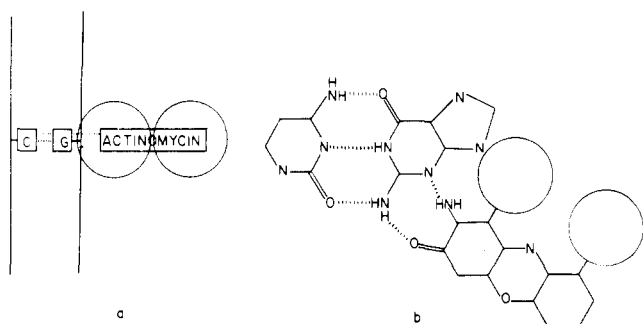

Figure 9. Schematic representation of Hamilton, Fuller, and Reich's model of the actinomycin-DNA complex: (a) front view, (b) top view. Circles represent pentapeptide lactones.

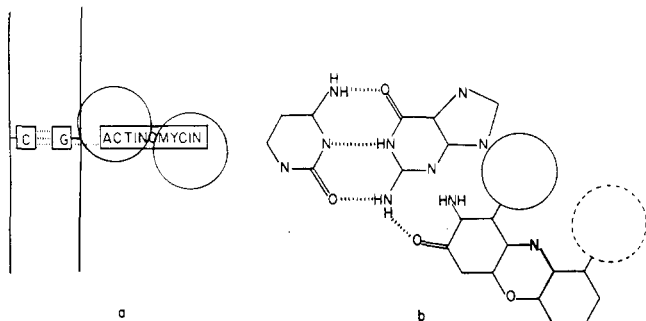

Figure 10. Schematic representation of Gurskii's model of the actinomycin-DNA complex: (a) front view, (b) top view. Circles represent pentapeptide lactones.

The conception of actinomycin-DNA complex was further refined with the discovery that a 2-amino group on a purine was required for binding;¹⁴⁷ 2,6-diaminopurine can replace dG as a binding factor. Two exceptions to the dG specificity are known. In one case the presence of dG is not required for binding. Single-stranded poly-dI binds actinomycin, possibly because of a peculiar conformation of the polymer.¹⁴³ In the other case the presence of dG is not sufficient for binding. Poly-d(A-T-C):poly-d(G-A-T) does not interact with actinomycin by spectrophotometric measurement, equilibrium dialysis, buoyant density, melting temperature and inhibition of RNA synthesis,^{143,148} and circular dichroism.¹⁴⁹ Again, this may be due to a difference in conformation or to the fact that actinomycin requires a specific base sequence not present in this polyl-trimer. Actinomycin is bound more tightly to a polydeoxyribonucleotide that contains both purines and pyrimidines on both strands than to the isomer with all purines on one strand and all pyrimidines on one complementary strand.¹⁴³

Actinomycin interferes with the RNA chain elongation step and not with the initiation or termination step. Kinetic studies have shown that specifically the CTP and GTP incorporation is slowed down.¹⁵⁰ This result has a bearing on the alternative between an inside or outside model for binding, since the data require the actinomycin not to be bound symmetrically with respect to a G-C pair and an adjacent pair (see section VII).

VII. Models for the Actinomycin-DNA Complex

During the last decade four models have been proposed for the complex between actinomycin and DNA. In two of these actinomycin is bound to the outside of the double-stranded DNA helix, while the other two represent *inside bound complexes* whereby the chromophore intercalates between two successive base pairs. There are arguments pro and con for these two types. Support for

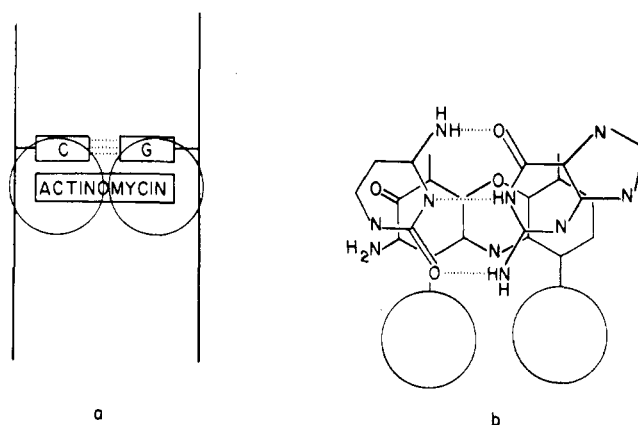

Figure 11. Schematic representation of Müller and Crothers model of the actinomycin-DNA complex: (a) front view, (b) top view. Circles represent pentapeptide lactones.

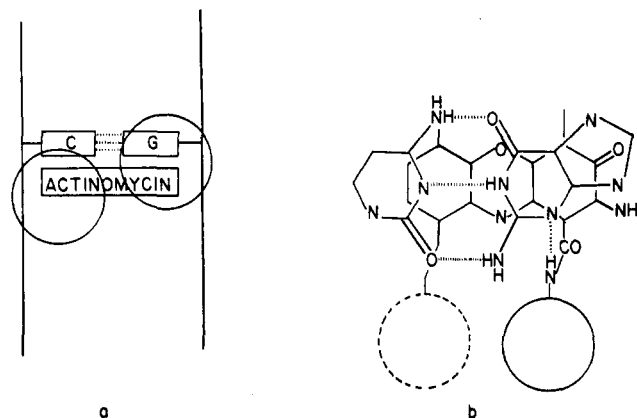

Figure 12. Schematic representation of Sobell and Jain's model of the actinomycin-DNA complex: (a) front view, (b) top view. Circles represent pentapeptide lactones.

the outside-binding models comes from (i) flow-dichroism studies showing an angle of 67° between the DNA axis and the transition moment of the visible absorption band of actinomycin,¹⁰⁷ (ii) decrease in DNA viscosity when actinomycin binds,¹⁰⁷ (iii) the fact that lengths of intact lambda virus DNA, as measured by the electron microscope, were not affected by actinomycin,¹⁵¹ (iv) kinetic evidence against the symmetrical placement of actinomycin with respect to two base pairs as in intercalation,¹⁵⁰ and (v) molecular model building. In support of the intercalation models stands the following evidence: (i) the length of the DNA molecule is increased by a remarkable 4-5 Å (base pair spacing = 3.4 Å) upon complex formation as evidenced by increased viscosity and decreased sedimentation coefficient of low molecular weight DNA ($M = 1 \times 10^5$) which behaves like rigid rods (opposite effects occur for high molecular weight DNA which is flexible);¹⁵² (ii) substitution of a 'bulky group' at the 7-position of actinomycin significantly reduces complex formation;¹⁵² (iii) a marked decrease in binding upon increased ionic strength can be related to a decrease in repulsion of adjacent phosphate groups through an electrostatic shielding effect;^{152,153} (iv) the unwinding of the supercoiled structure of the replicative form of bacteriophage, ϕ X174 DNA, can be interpreted on the basis of intercalation¹⁵⁴⁻¹⁵⁶ although an unwinding pressure exerted by the polypeptide moieties could also be the cause; (v) the structure of the actinomycin-dG₂ complex²⁴ shows clearly the steric fit in an intercalative model; and (vi) molecular model building supports.

The first model (Figure 9) depicts actinomycin in the

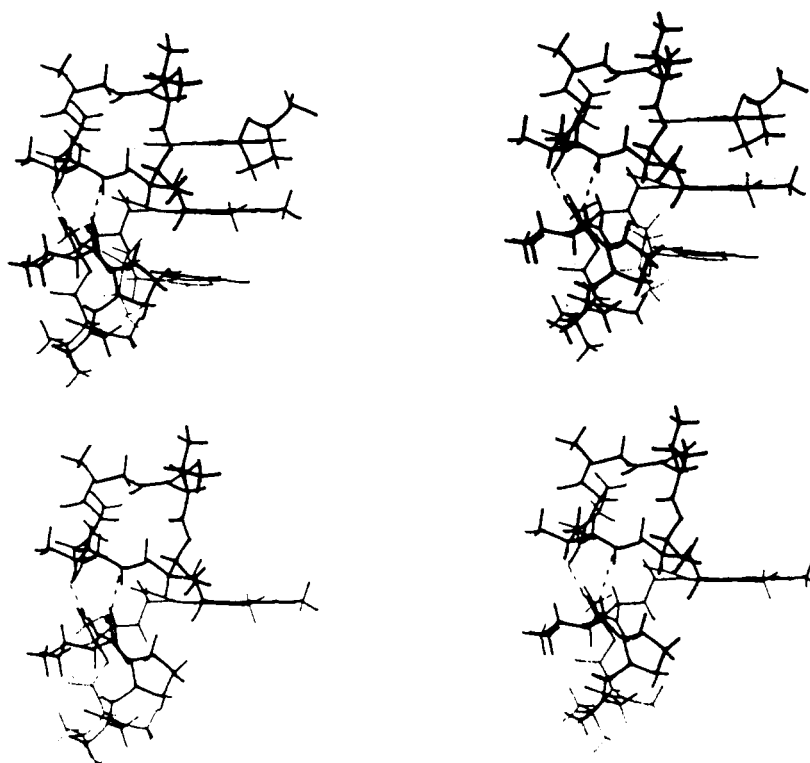

Figure 13. Computer-generated stereopairs showing the first step in the assembly of the actinomycin-DNA model. The bottom pair represents actinomycin viewed perpendicular to its dyad axis in the direction benzenoid to quinoid ring. In the top pair two deoxyguanosines have been added (after Sobell¹⁵⁶ with permission).

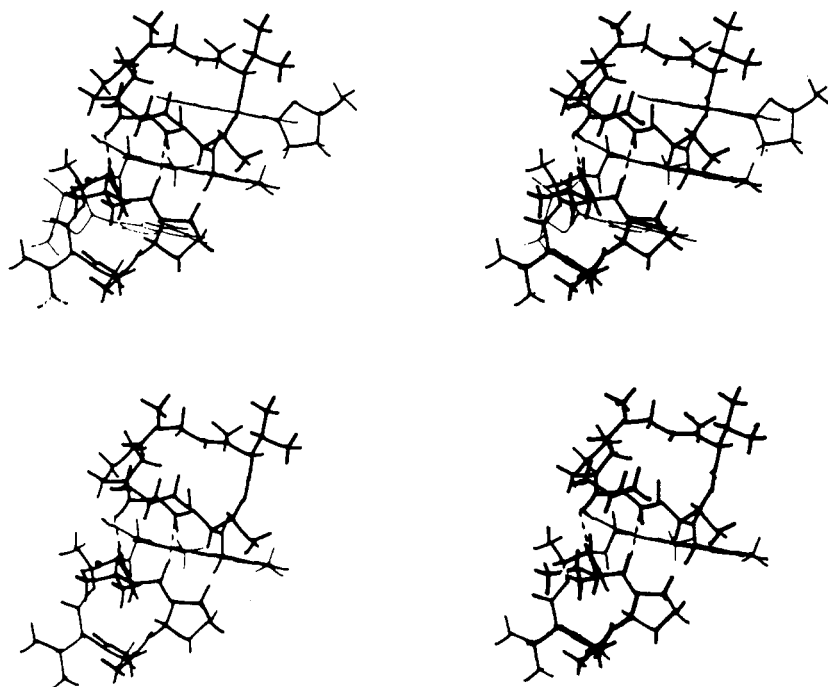

Figure 14. As in Figure 13, but turned $\sim 45^\circ$.

minor groove of helical DNA.¹³³ Hydrogen bonds between $C_3=O$ and the 2-amino group of guanine and between C_2-NH_2 and both the guanine- N_3 and the deoxyribose ring oxygen stabilize this outside complex. The peptide lactones permit further stabilization through four hydrogen bonds between four NH groups and the phosphodiester oxygens. The minor groove is occupied over three nucleotide pairs. Thus, for every actinomycin bound at least two guanine residues are blocked. The relationship of occupied sites vs. dG content is accounted for by this

model, although it permits somewhat higher saturation values than actually observed.

A second similar "outside" model (Figure 10) places actinomycin in the minor groove, with an angle of 20° between the chromophore and the base planes.¹⁵⁷ Hydrogen bonds exist between the C_2-NH_2 and the phosphate oxygen of DNA and between the $C_3=O$ and the 2-amino group of guanine. Some uncoiling of the DNA helix is required. The two peptide rings are on opposite sides of the chromophore, thus occupying a longer DNA segment

TABLE IX. Biological Activities of Natural Actinomycins and Synthetic Analogs

Compound	Activity, $\mu\text{g}/\text{ml}^a$	Method of expression	Ref		
Actinomycin C ₁	0.25	Concn required to inhibit growth of <i>B. subtilis</i>	60		
Actinomycin C ₂	0.25				
Actinomycin C ₃	0.25				
Actinomycin F ₁	1.0				
Actinomycin X _{0β}	1.5				
Actinomycin X _{0δ}	0.35				
N-Methylactinomycin C ₂	1.0				
N-(β -Dimethylamino)actinomycin C ₃	2.5				
Deaminoactinomycin C ₃	10				
Chloroactinomycin C ₃	10				
N-(<i>p</i> -Aminophenyl)actinomycin C ₃	10				
N-Aminoactinomycin C ₃	10				
Actinomycin C ₁	70			100 \times minimal inhibitory (<i>B. subtilis</i>) concn of actinomycin C ₃ ; minimal inhib- itory concn of cpd in first column	100
Actinomycin X _{0α}	1.5				
Actinomycin X _{0β}	2.5				
Actinomycin X _{0γ}	30				
Actinomycin X _{0δ}	40				
Actinomycin X _{1a}	70				
Actinomycin X ₂	150				
Actinomycin C ₁	1:20 \times 10 ⁶	Minimal inhibitory concn (<i>B. subtilis</i>)	61		
Actinomycin X ₂	1:30 \times 10 ⁶				
Actinomycin X _{0δ}	1:10 \times 10 ⁶				
Actinomycin X _{0β}	1:0.5 \times 10 ⁶				
Actinomycin X _{0δ} acetate	1:2.5 \times 10 ⁶				
Actinomycin X _{0β} acetate	1:1.5 \times 10 ⁶				
7-Bromoactinomycin C ₃	1:4 \times 10 ⁶				
7-Hydroxyactinomycin C ₁ , pH 6.0	1:0.5 \times 10 ⁶				
7-Hydroxyactinomycin C ₁ , pH 7.1	1:5 \times 10 ³				
7-Nitro actinomycin C ₁	1:10 \times 10 ⁶				
7-Aminoactinomycin C ₂	1:2 \times 10 ⁶				
7-Methoxyactinomycin C ₁	1:2 \times 10 ⁶				
Deaminoactinomycin C ₂	1:8 \times 10 ³				
3-Chloroactinomycin C ₂	1:2 \times 10 ⁴				
N-Methylactinomycin C ₂	1:2 \times 10 ⁶				
N-(β -Hydroxyethyl)actinomycin C ₂	1:6.4 \times 10 ⁴				
N-Dimethyleneactinomycin C ₃	1:4 \times 10 ³				
N-(β -Diethylaminoethyl)- actinomycin C ₃	1:20 \times 10 ³				
N-(<i>p</i> -Aminophenyl)actinomycin C ₃	1:3.2 \times 10 ⁴				
N-(β -Aminoethyl)actinomycin C ₃	1:6.4 \times 10 ⁴				
N-Trimethyleneactinomycin C ₃	1:6.4 \times 10 ⁴				
N-Isopropylactinomycin C ₃	1:5 \times 10 ³				
N-Cyclohexylactinomycin C ₃	1:5 \times 10 ³				
N-(α -Carbomethoxyethyl)- actinomycin C ₃	1:5 \times 10 ³				
N-(β -Chloroethyl)actinomycin C ₂	1:6.4 \times 10 ⁴				
Actinocin	Inactive				
<i>seco</i> -Actinomycin C ₃	Inactive				
Bis(<i>seco</i> -actinomycin C ₃)	Inactive				
Actinomycinic (C ₃) acid	Inactive				
Actinomycin C ₁ with L-Ser instead of L-Thr	8 \times	Min inhibitory concn (<i>B. subtilis</i>) relative to actinomycin C ₃	71		
Actinomycin Z ₁	50 \times	Min inhibitory concn (<i>B. subtilis</i>) relative to actinomycin C ₃	9		
Enantiomer of actinomycin C ₁	Inactive	Activity against <i>B. subtilis</i>	72		
7-Hydroxyactinomycin C ₂	<0.25%	Activity against <i>B. subtilis</i> relative to that of actinomycin C ₃	80		
7-Nitroactinomycin C ₂	40%				
7-Aminoactinomycin C ₂	<1%				
7-Chloroactinomycin C ₃	50%				
2-Deamino-2-chloro- 7-bromoactinomycin C ₃	Inactive				
7-Bromoactinomycin C ₃	150%	Complexing with DNA	159		
Actinocyl-gramicidin S	None				
Actinomycin C ₃ with D-Leu instead of D- α -Ile	25%	Activity against <i>B. subtilis</i> relative to that of actinomycin C ₃	54		
Actinomycin C ₁ with L-Ser instead of L-Thr	20%				
Actinomycin C ₁ or C ₃ with D-Ala instead of D-Val or D- α -Ile	1%				

TABLE IX (Continued)

Actinomycin D	0.02	Min inhibitory concn against	30
Actinomycin pip 1 α	0.25	<i>B. subtilis</i>	
Actinomycin pip 1 β	0.02		
Actinomycin pip 2	0.1		
Various actinomycins with α or β ring truncated or open	Inactive	Activity against <i>B. subtilis</i>	25
Various natural actinomycins	0.05-12	Min inhibitory concn against <i>B. subtilis</i>	28
4,6-Didemethylactinomycin C ₁	0.01	Activity against <i>B. subtilis</i> relative	86
4,6-Didemethyl-4,6- dimethoxyactinomycin C ₁	0.01	to that of actinomycin C ₁	
4,6-Didemethyl-4,6-diethyl- actinomycin C ₁	0.5		
4,6-Didemethyl-4,6-di- <i>tert</i> - butylactinomycin C ₁	0		
4,6-Didemethyl-4,6- dibromoactinomycin C ₁	23%	Activity against <i>B. subtilis</i> relative	89
Actinomycin D lactam	0.5	ID ₅₀ <i>L. arabinosus</i>	73, 74
[Gly ^{4'} , Val ^{6'}]actinomycin D	0	Activity against <i>B. subtilis</i>	75

^a Except where noted.

than in the previous model. The entire molecule covers about six base pairs, fitting the binding data closely.

In the third model (Figure 11) the actinomycin chromophore is intercalated between two successive base pairs,¹⁵² one of which is G:C, with the peptide rings projecting into the minor groove. Stabilization occurs in a number of ways: through electronic interaction of the chromophore π complex and the guanine 2-amino group and through hydrogen bonds between the carboxamide NH to the deoxyribose ring oxygen. Several forms of this complex are thought to exist at equilibrium. In the most stable form the two peptide rings, after having undergone conformational changes, interact with each strand in the minor groove of the double helix. The slow reversal of these conformations is responsible for the slow association-dissociation which in turn is the basis for the high effectiveness of the antibiotic, in preventing the RNA polymerase of progressing along the DNA.²⁰ The disso-

ciation is characterized by three time constants (12, 44, and 570 sec), which may correspond to three different binding sites on DNA. When only one peptide ring complexes, the time constant is either 12 or 44 sec. When both peptides interact, the time constant should be the product, 540, as experimentally verified.¹³⁵

The fourth and most recent model (Figures 12-15) is based on the structure of the crystalline actinomycin-dG₂ complex and combines the guanine 2-amino group specificity of the first two models with the intercalative feature of the third.^{24,158} The phenoxazone chromophore intercalates between adjacent G-C pairs where the guanine residues are on opposite strands. The 2-amino groups of guanine binds to C=O_{Thr} of the peptide rings which lie in the minor groove, trans with respect to the plane of the chromophore. The NH_{Val} is bound to the C=O_{Val} of the other ring and *vice versa*. Since in the uncomplexed actinomycin molecule these groups may be involved in *intra*

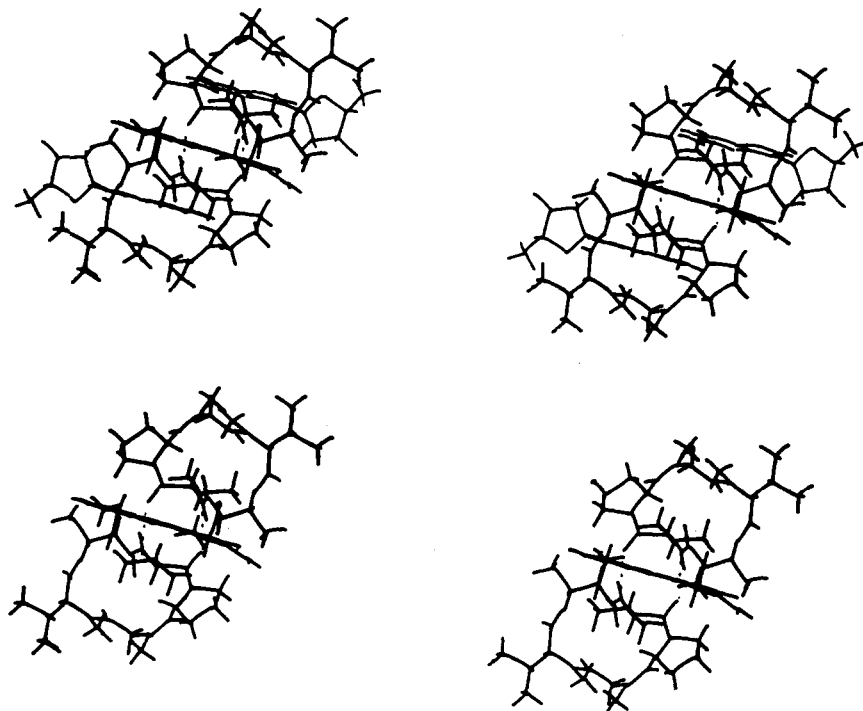

Figure 15. As in Figure 13, but viewed along the dyad axis.

cyclopeptide hydrogen bonding,^{116,120} the breakage of these and subsequent formation of new hydrogen bonds may provide a physical explanation for the slow conformational adjustments of the peptide lactones as suggested by the kinetic data of Müller and Crothers.¹⁵²

Sobell's model has quasi- C_2 symmetry in the immediate vicinity of the actinomycin chromophore, as in the actinomycin-dG₂ complex.¹²⁵ It predicts that poly-d(G-C):poly-d(G-C) which contains the alternating sequence GpC should bind actinomycin best, although other sequences containing guanine can bind the antibiotic, but with lower efficiency. This picture does not seem to be supported by Gellert's data.¹⁰⁷ Binding data of Wells, however, seem to support the model.¹⁴³

The model explains most data concerning the binding of the antibiotic to DNA. It has received a high level of confidence throughout the scientific community. It is of interest that the model possibly demonstrates a general principle which several classes of proteins utilize in recognizing symmetrically arranged nucleotide sequences on the DNA helix. If a protein molecule, e.g., a repressor, has identical subunits related by C_2 symmetry when it binds to DNA and the C_2 axis coincides with the dyad axis in DNA, then a necessary consequence is that the base sequence in the recognition site, e.g., an operator, have C_2 symmetry.²⁴

VIII. Biological Activity

Actinomycin is one of the most potent antitumor agents known. Unfortunately, it has found only limited use clinically because of its extreme toxicity. It is, therefore, not surprising that numerous investigators have synthesized actinomycin analogs (see section II.D) in the hope of enhancing the biological activity or at least to improve the chemotherapeutic index (maximum tolerable dose over minimum curative dose). As the picture of the mechanism of action of actinomycin emerges (see section VII), it becomes increasingly clear that the potency of actinomycin is due to a high specificity which requires a precise and unique steric fit between the two molecules DNA and actinomycin. Any change in either molecule that will interfere with this sensitive geometry of the binding complex will render the system less active or inactive. It is remarkable that natural actinomycins seem to provide already an optimum combination between the antibiotic and the polydeoxyribonucleotide and that any attempt to improve their activity has failed. Improvement of the chemotherapeutic index, however, is a different problem which is related to a difference in cell wall permeability of the healthy and the unwanted cell. Many possibilities remain open in this area. Fascinating suggestions have been made by Sobell²⁴ after he could ascertain on the basis of his model which groups could be altered without affecting the steric fit of the actinomycin-DNA complex.

While the naturally occurring actinomycins differ only slightly in their activity, any changes in different portions of a synthetic actinomycin molecule may affect its inhibitory activity to a greater or lesser extent.^{13,17,152} The presence of several groups is essential: the unaltered C_2-NH_2 and $C_3=O$ groups and the intact pentapeptide lactones. Of interest is the replacement of the two pentapeptide lactones by the monocyclic peptide system of the antibiotic gramicidin S.¹⁵⁹ The resulting actinocyl-gramicidin S did not complex with DNA and did not inhibit RNA synthesis.

The activities of various actinomycins and actinomycin analogs are listed in Table IX.

IX. Addendum

After submission of the manuscript, additional publications have come to the attention of the author. These update the review through September 1974.

Structure-activity relations were reviewed by Meienhofer.¹⁶⁰ The cancer chemotherapy aspects were reviewed in the Selman A. Waksman Conference on Actinomycins. The conference comprises, among others, reports on the modification of actinomycin molecules, the synthesis of analogs of actinomycin, 7-substituted actinomycin analogs as fluorescent DNA-binding and experimental antitumor agents, controlled biosynthesis of actinomycins, actinomycin monolactones, origins of the base specificity in actinomycin and other DNA ligands, and the stereochemistry of actinomycin binding to DNA. In addition, several chemotherapeutical and pharmacological aspects are discussed.¹⁶¹

Reverse-phase high-pressure liquid chromatography of actinomycins was investigated.¹⁶²

Several new actinomycins were discovered. Actinomycin Z contains 3-hydroxy-4-oxo-5-methylproline.¹⁶³ Z₅ contains L-4-oxo-5-methylproline, L-MePro, and L-MeAla.¹⁶⁴ An actinomycin D₀ was isolated with one Sar replaced by one Gly.¹⁶⁵ The cis configuration of 5-MePro in actinomycin Z₅ was established.¹⁶⁶

Actinomycin monolactones were investigated.¹⁶⁷ The role of 3-hydroxy-4-methylkynurenine in the biosynthesis of actinomycin was studied.¹⁶⁸

A conformational analysis of actinomycin¹⁶⁹ and of dimethyl actinocynilbis(L-threonate)¹⁷⁰ is discussed. The atomic coordinates of actinomycin obtained by X-ray analysis by Sobell have been refined to fit a set of standard bond lengths and bond angles.¹⁷¹

Lackner reported on conformations and interannular relationships of free and one-sidedly fixed pentapeptide lactones by nmr.¹⁷² The ¹³C spectrum of actinomycin has been measured and interpreted on the basis of numerous model compounds.¹⁷³

The interactions of actinomycin with several deoxydinucleotides were studied by 100 MHz pmr at different nucleotide to drug ratio. pdG-dC formed an intercalated type complex.¹³⁷ Similarly the structure of the 1:2 complex of actinomycin with D-GMP was investigated by nmr by monitoring the chemical shifts of ¹H, ¹³C, and ³¹P.¹⁷⁴

The stereochemistry of actinomycin binding to DNA was discussed.¹⁷⁵ A small angle X-ray scattering study on the interaction of actinomycin C₃ with calf thymus DNA has been reported.¹⁷⁶

X. References

- (1) J. Meienhofer, *J. Amer. Chem. Soc.*, **92**, 3771 (1970); *Experientia*, **24**, 776 (1968).
- (2) S. A. Waksman and H. B. Woodruff, *Proc. Soc. Exp. Biol. Med.*, **45**, 609 (1940).
- (3) C. E. Dagliesh and A. R. Todd, *Nature (London)*, **164**, 830 (1949).
- (4) C. E. Dagliesh, A. W. Johnson, A. R. Todd, and L. C. Vining, *J. Chem. Soc.*, 2946 (1950).
- (5) H. Brockmann and N. Grubhofer, *Naturwissenschaften*, **36**, 376 (1949).
- (6) H. Brockmann, W. Sunderkötter, K. W. Ohly, and P. Boldt, *Naturwissenschaften*, **47**, 230 (1960).
- (7) A. Butenandt, *Angew. Chem.*, **69**, 16 (1957).
- (8) G. W. K. Cavill, P. S. Clezy, J. R. Tetaz, and R. L. Werner, *Tetrahedron*, **5**, 275 (1959).
- (9) H. Brockman and J. H. Manegold, *Hoppe-Seyler's Z. Phys. Chem.*, **343**, 86 (1966).
- (10) A. W. Johnson, *Chem. Soc., Spec. Publ.*, No. 5, 82 (1956).
- (11) A. W. Johnson, *Ciba Found. Symp.*, 123 (1958).
- (12) H. Brockmann, *Angew. Chem.*, **72**, 939 (1960).
- (13) H. Brockmann, *Fortschr. Chem. Org. Naturst.*, **18**, 1 (1960).
- (14) Conference on the actinomycins and their importance in the treatment of tumors in animals and man, March 31-April 1, 1960; *Ann. N. Y. Acad. Sci.*, **89**, 283 (1960). Containing articles by H. Brockmann, p 323 and A. W. Johnson, p 336.
- (15) H. Brockmann, *Pure Appl. Chem.*, **2**, 405 (1961).

- (16) J. Kawamata, *Kagaku No Ryoiki*, **16**, 822 (1962).
- (17) E. Reich and I. H. Goldberg, *Progr. Nucl. Acid Res.*, **3**, 183 (1964).
- (18) E. Reich, *Symp. Soc. Study Develop. Growth*, **23**, 73 (1964).
- (19) E. Reich, A. Cerami, and D. C. Ward, "Antibiotics I, Mechanism of Action," D. Gottlieb and P. D. Shaw, Ed., Springer-Verlag, New York, N. Y., 1967, p 714.
- (20) G. Hartmann, W. Behr, K. A. Beissner, K. Honikel, and A. Sippel, *Angew. Chem., Int. Ed. Engl.*, **7**, 693 (1968).
- (21) I. H. Goldberg and P. A. Friedman, *Annu. Rev. Biochem.*, **40**, 772 (1971).
- (22) I. H. Goldberg and P. A. Friedman, *Pure Appl. Chem.*, **28**, 499 (1971).
- (23) E. F. Gale, E. Cundliffe, P. E. Reynolds, M. H. Richmond, and M. J. Waring, "The Molecular Basis of Antibiotic Action," Wiley, New York, N. Y., 1972, p. 220.
- (24) H. Sobell, *Progr. Nucl. Acid Res. Mol. Biol.*, **13**, 153 (1973).
- (25) H. Lackner, *Chem. Ber.*, **103**, 2476 (1970).
- (26) E. Katz in "Actinomycin," S. A. Waksman, Ed., Wiley, New York, N. Y., 1968, Chapter 4.
- (27) E. Katz and H. Weissbach, *Develop. Ind. Microbiol.*, **8**, 67 (1967).
- (28) E. Katz, "Antibiotics II, Biosynthesis," D. Gottlieb and P. D. Shaw, Ed., Springer-Verlag, New York, N. Y., 1967, p 276.
- (29) J. V. Formica, *Diss. Abstr., B*, **28** (8), 3398 (1967).
- (30) J. V. Formica, A. J. Shatkin, and E. Katz, *J. Bacteriol.*, **95**, 2139 (1968).
- (31) J. V. Formica and E. Katz, *J. Biol. Chem.*, **248**, 2066 (1973).
- (32) J. E. Walker, S. Otani, and D. Perlman, *FEBS (Fed. Eur. Biochem. Soc.) Lett.*, **20**, 162 (1972).
- (33) H. Weissbach, B. G. Redfield, V. Beaven, and E. Katz, *J. Biol. Chem.*, **240**, 4377 (1965).
- (34) H. Weissbach, B. Redfield, V. Beaven, and E. Katz, *Biochem. Biophys. Res. Commun.*, **19**, 524 (1965).
- (35) E. Katz and H. Weissbach, *J. Biol. Chem.*, **237**, 882 (1962).
- (36) J. P. Marsh, Jr., and L. Goodman, *Can. J. Chem.*, **44**, 799 (1966).
- (37) H. Brockmann, H. Lackner, R. Mecke, G. Troemel, and H. S. Petras, *Chem. Ber.*, **99**, 717 (1966).
- (38) H. Brockmann and W. Sunderkötter, *Naturwissenschaften*, **47**, 229 (1960).
- (39) H. Brockmann and H. Lackner, *Naturwissenschaften*, **47**, 230 (1960).
- (40) H. Brockmann and H. S. Petras, *Naturwissenschaften*, **48**, 218 (1961).
- (41) H. Brockmann, H. Lackner, R. Mecke, S. von Grunelius, H. S. Petras, and H. D. Berndt, *Chem. Ber.*, **99**, 3672 (1966).
- (42) H. Brockmann and H. Lackner, *Naturwissenschaften*, **48**, 555 (1961).
- (43) H. Brockmann and H. Bujard, *Naturwissenschaften*, **49**, 515 (1962).
- (44) H. Brockmann and V. Graef, *Naturwissenschaften*, **49**, 541 (1962).
- (45) H. Brockmann and W. Schramm, *Tetrahedron Lett.*, 2331 (1966).
- (46) H. Brockmann and H. Lackner, *Chem. Ber.*, **100**, 353 (1967).
- (47) R. B. Woodward, R. A. Olofson, and H. Mayer, *J. Amer. Chem. Soc.*, **83**, 1010 (1961).
- (48) H. A. Staab, *Angew. Chem.*, **74**, 407 (1962).
- (49) R. A. Boissonas and J. Schumann, *Helv. Chim. Acta*, **35**, 2229 (1952).
- (50) H. Brockmann and J. H. Manegold, *Naturwissenschaften*, **51**, 383 (1964).
- (51) H. Brockmann and J. H. Manegold, *Chem. Ber.*, **100**, 3814 (1967).
- (52) H. Brockmann and H. Lackner, *Naturwissenschaften*, **51**, 384 (1964).
- (53) H. Brockmann and H. Lackner, *Naturwissenschaften*, **51**, 407 (1964).
- (54) H. Brockmann and H. Lackner, *Chem. Ber.*, **101**, 1312 (1968).
- (55) H. Brockmann and H. Lackner, *Naturwissenschaften*, **51**, 435 (1964).
- (56) H. Brockmann and H. Lackner, *Tetrahedron Lett.*, 3517 (1964).
- (57) H. Brockmann and H. Lackner, *Chem. Ber.*, **101**, 2231 (1968).
- (58) H. Wanzlik, *Angew. Chem., Int. Ed., Engl.*, **3**, 401 (1964).
- (59) H. Brockmann and E. Schulze, *Chem. Ber.*, **102**, 3205 (1969).
- (60) E. Reich, I. H. Goldberg, and M. Rabinowitz, *Nature (London)*, **196**, 743 (1962).
- (61) W. Müller, *Naturwissenschaften*, **49**, 156 (1962).
- (62) H. Lackner, *Chem. Ber.*, **104**, 3653 (1971).
- (63) H. Lackner, *Tetrahedron Lett.*, 3189 (1970).
- (64) J. Meienhofer, *J. Org. Chem.*, **32**, 1143 (1967).
- (65) D. T. Warner, *Nature (London)*, **190**, 120 (1961).
- (66) H. G. Bachmann and W. Müller, *Nature (London)*, **201**, 261 (1964).
- (67) H. Brockmann and P. Boldt, *Naturwissenschaften*, **50**, 19 (1963).
- (68) H. Brockmann and P. Boldt, *Chem. Ber.*, **101**, 1940 (1968).
- (69) H. Brockmann and J. H. Manegold, *Chem. Ber.*, **93**, 971 (1960).
- (70) H. Brockmann, G. Pampus, and J. H. Manegold, *Chem. Ber.*, **92**, 1294 (1959).
- (71) H. Brockmann and H. Lackner, *Tetrahedron Lett.*, 3523 (1964).
- (72) H. Brockmann and W. Schramm, *Tetrahedron Lett.*, 2331 (1966).
- (73) E. Atherton and J. Meienhofer, *J. Amer. Chem. Soc.*, **94**, 4759 (1972).
- (74) E. Atherton, R. P. Patel, Y. Sano, and J. Meienhofer, *J. Med. Chem.*, **16**, 355 (1973).
- (75) C. W. Mosher and L. Goodman, *J. Org. Chem.*, **37**, 2928 (1972).
- (76) W. A. Gray, *Diss. Abstr. B*, **27**, 751 (1966).
- (77) H. Brockmann and B. Franck, *Angew. Chem.*, **68**, 68 (1956).
- (78) H. Brockmann, G. Pampus, and R. Mecke, *Chem. Ber.*, **92**, 3082 (1959).
- (79) H. Brockmann, J. Amman, and W. Müller, *Tetrahedron Lett.*, 3595 (1966).
- (80) H. Brockmann, W. Müller, and H. Peterssen-Borstel, *Tetrahedron Lett.*, 3531 (1966).
- (81) H. Brockmann, P. Hocks, and W. Müller, *Chem. Ber.*, **100**, 1051 (1967).
- (82) S. G. Levene and M. C. Wani, *J. Org. Chem.*, **30**, 3185 (1965).
- (83) M. C. Wani and S. G. Levene, *J. Org. Chem.*, **31**, 2564 (1966).
- (84) H. Brockmann and F. Seela, *Tetrahedron Lett.*, 4803 (1965); 161 (1968).
- (85) F. Seela, *Z. Naturforsch. B*, **26**, 875 (1971).
- (86) H. Brockmann and F. Seela, *Chem. Ber.*, **104**, 2751 (1971).
- (87) H. Brockmann, W. Müller, and H. Peterssen-Borstel, *Tetrahedron Lett.*, 3531 (1966).
- (88) H. Brockmann, J. Amman, and W. Müller, *Tetrahedron Lett.*, 3595 (1966).
- (89) F. Seela, *J. Med. Chem.*, **15**, 684 (1972).
- (90) E. N. Glibin and O. F. Ginzburg, *Khim. Geterotsikl. Soedin.*, **40** (1969); *Chem. Abstr.*, **71**, 61306s (1969).
- (91) E. N. Glibin, Z. I. Korshunova, O. F. Ginzburg, and L. F. Larionov, *Khim. Geterotsikl. Soedin.*, **602** (1969); *Chem. Abstr.*, **72**, 32187u (1970).
- (92) E. N. Glibin, Z. I. Korshunova, O. F. Ginzburg, and L. F. Larionov, *Chem. Heterocycl. Compounds (USSR)*, *Engl. Trans.*, **5**, 445 (1969).
- (93) V. G. Sinitsyn, E. N. Glibin, and O. F. Ginzburg, *Zh. Org. Khim.*, **6**, 500 (1970); *Chem. Abstr.*, **72**, 132640e (1970).
- (94) Z. I. Korshunova, E. N. Glibin, E. R. Zakhs, and O. F. Ginzburg, *Zh. Org. Khim.*, **6**, 510 (1970); *Chem. Abstr.*, **72**, 132647n (1970).
- (95) Z. I. Korshunova, E. R. Zakhs, and O. F. Ginzburg, *Zh. Org. Khim.*, **6**, 504 (1970); *Chem. Abstr.*, **72**, 133158r (1970).
- (96) E. N. Glibin, V. G. Sinitsyn, and O. F. Ginzburg, *Zh. Org. Khim.*, **6**, 1020 (1970); *Chem. Abstr.*, **73**, 35726a (1970).
- (97) E. N. Glibin, V. G. Sinitsyn, and O. F. Ginzburg, *Zh. Org. Khim., Engl. Trans.*, **6**, 1023 (1970).
- (98) E. N. Glibin, Z. I. Korshunova, V. G. Sinitsyn, E. R. Zakhs, O. F. Ginzburg, L. S. Rakhimbekova, and V. S. Gaitskhoki, *Puti Sin. Izysskaniya Protivoopukholevykh Prep.*, 1968, 179 (1970); *Chem. Abstr.*, **75**, 76700x (1971).
- (99) M. T. Wu and R. E. Lyle, *J. Heterocycl. Chem.*, **8**, 989 (1971).
- (100) H. Brockmann and J. H. Manegold, *Chem. Ber.*, **95**, 1081 (1962).
- (101) H. Brockmann and E. A. Stahler, *Naturwissenschaften*, **52**, 391 (1965).
- (102) W. Kersten, H. Kersten, and H. M. Rauen, *Nature (London)*, **187**, 60 (1960).
- (103) M. F. Perutz, *Nature (London)*, **201**, 814 (1964).
- (104) H. T. Palmer, R. A. Palmer, and R. E. Dickerson, *Nature (London)*, **202**, 1052 (1964).
- (105) W. Müller and I. Ennie, *Z. Naturforsch. B*, **20**, 835 (1965).
- (106) H. Berg, *J. Electroanal. Chem.*, **10**, 371 (1965).
- (107) M. Gellert, C. E. Smith, D. Neville, and G. Felsfeld, *J. Mol. Biol.*, **11**, 445 (1965).
- (108) Y. Courtois, W. Guschlbauser, and P. Fromageot, *Eur. J. Biochem.*, **6**, 106 (1968).
- (109) D. M. Crothers, S. L. Sabol, D. I. Ratner, and W. Müller, *Biochemistry*, **7**, 1817 (1968).
- (110) F. Ascoli, P. De Santis, and M. Savino, *Nature (London)*, **227**, 1237 (1970).
- (111) F. Ascoli, P. De Santis, M. Lener, and M. Savino, *Biopolymers*, **11**, 1173 (1972).
- (112) H. Ziffer, K. Yamaska, and A. B. Mauger, *Biochemistry*, **7**, 996 (1968).
- (113) N. S. Angerman, T. A. Victor, C. L. Bell, and S. S. Danyluk, *Biochemistry*, **11**, 2402 (1972).
- (114) T. A. Victor, F. E. Hruska, C. L. Bell, and S. S. Danyluk, *Tetrahedron Lett.*, 4721 (1969).
- (115) B. H. Arison and K. Hoogsteen, *Biochemistry*, **9**, 3976 (1970).
- (116) T. A. Victor, F. E. Hruska, K. Hikichi, S. S. Danyluk, and C. L. Bell, *Nature (London)*, **223**, 302 (1969).
- (117) S. S. Danyluk and T. A. Victor, *Jerusalem Symp. Quant. Chem. Biochem.*, **2**, 394 (1970).
- (118) H. Lackner, *Tetrahedron Lett.*, 2807 (1970).
- (119) H. Lackner, *Tetrahedron Lett.*, 2221 (1971).
- (120) F. Conti and P. De Santis, *Nature (London)*, **227**, 1239 (1970).
- (121) P. De Santis, R. Rizzo, and G. Ughetto, *Nature (London)*, **237**, 94 (1972).
- (122) P. De Santis, R. Rizzo, and G. Ughetto, *Biopolymers*, **11**, 279 (1972).
- (123) H. M. Sobell, S. C. Jain, and T. D. Sakore, *Nature (London)*, *New Biol.*, **231**, 200 (1971).
- (124) H. M. Sobell, S. C. Jain, T. D. Sakore, and G. Ponticello, *Cold Spring Harbor Symp. Quant. Biol.*, **37**, 263 (1972).
- (125) S. C. Jain and H. M. Sobell, *J. Mol. Biol.*, **68**, 1 (1972).
- (126) W. Kersten, *Biochim. Biophys. Acta*, **47**, 610 (1961).
- (127) B. Pullman, *Biochim. Biophys. Acta*, **88**, 440 (1964).
- (128) E. Reich, *Science*, **143**, 684 (1964).
- (129) W. Müller and H. C. Spatz, *Z. Naturforsch. B*, **20**, 842 (1965).
- (130) M. T. A. Behme and E. H. Cordes, *Biochim. Biophys. Acta*, **108**, 312 (1965).
- (131) D. M. Crothers and D. I. Ratner, *Biochemistry*, **7**, 1823 (1968).
- (132) R. B. Homer, *Arch. Biochem. Biophys.*, **129**, 405 (1969).
- (133) L. Hamilton, W. Fuller, and E. Reich, *Nature (London)*, **198**, 538 (1963).
- (134) R. Schara and W. Müller, *Eur. J. Biochem.*, **29**, 210 (1972).

- (135) T. R. Krugh, *Proc. Nat. Acad. Sci. U. S.*, **69**, 1911 (1972).
- (136) T. R. Krugh and J. W. Neely, *Biochemistry*, **12**, 1775 (1973).
- (137) T. R. Krugh and J. W. Neely, *Biochemistry*, **12**, 4418 (1973).
- (138) H. J. Robinson and S. A. Waksman, *J. Pharm. Exp. Therap.*, **74**, 25 (1942).
- (139) I. H. Goldberg, M. Rabinowitz, and E. Reich, *Proc. Nat. Acad. Sci. U. S.*, **48**, 2094 (1962).
- (140) G. Hartmann, U. Coy, and G. Kniese, *Hoppe-Seylers. Z. Phys. Chem.*, **330**, 227 (1963).
- (141) K. Yamoaka and H. Ziffer, *Biochemistry*, **7**, 1001 (1968).
- (142) M. Gold and J. Hurwitz, *J. Biol. Chem.*, **329**, 3866 (1964).
- (143) R. D. Wells and J. E. Larson, *J. Mol. Biol.*, **49**, 319 (1970).
- (144) R. W. Hyman and N. Davidson, *Biochem. Biophys. Res. Commun.*, **26**, 116 (1967).
- (145) N. R. Ringertz and L. Bolund, *Biochim. Biophys. Acta*, **174**, 147 (1969).
- (146) R. W. Hyman and N. Davidson, *Biochim. Biophys. Acta*, **228**, 38 (1971).
- (147) A. Cerami, E. Reich, D. C. Ward, and I. H. Goldberg, *Proc. Nat. Acad. Sci. U. S.*, **57**, 1036 (1967).
- (148) R. D. Wells, *Science*, **165**, 76, (1969).
- (149) Reference deleted in revision.
- (150) R. W. Hyman and N. Davidson, *J. Mol. Biol.*, **50**, 421 (1970).
- (151) L. G. Caro, *Virology*, **25**, 226 (1965).
- (152) W. Müller and D. M. Crothers, *J. Mol. Biol.*, **35**, 251 (1968).
- (153) B. A. K. Chibber, A. Balasubramanian, and T. Viswanatha, *Can. J. Biochem.*, **51**, 204 (1973).
- (154) M. J. Waring, *Biochem. J.*, **109**, 28P (1968).
- (155) M. J. Waring, *J. Mol. Biol.*, **54**, 247 (1970).
- (156) J. C. Wang, *Biochim. Biophys. Acta*, **232**, 246 (1971).
- (157) G. V. Gurskii, *Mol. Biol.*, **3**, 749 (1969); *Mol. Biol. (USSR)*, **3**, 292 (1970).
- (158) H. M. Sobell and S. C. Jain, *J. Mol. Biol.*, **68**, 21 (1972).
- (159) A. B. Manger and R. Wade, *J. Chem. Soc. C*, 1406 (1966).
- (160) J. Meienhofer, *Advan. Appl. Microbiol.*, **16**, 203 (1973).
- (161) *Cancer Chemother. Rep., Part 1*, **58**, 1 (1974).
- (162) W. J. Rzeszotarski and A. B. Mauger, *J. Chromatogr.*, **86**, 246 (1973).
- (163) H. Brockmann and E. A. Staehler, *Tetrahedron Lett.*, 3685 (1973).
- (164) H. Brockmann and E. A. Staehler, *Tetrahedron Lett.*, 2567 (1973).
- (165) M. L. Devan, T. I. Orlova, and A. B. Silaev, *Antibiotiki (USSR)*, **19**, 107 (1974).
- (166) E. Katz, K. T. Mason, and A. B. Mauger, *Biochem. Biophys. Res. Commun.*, **52**, 819 (1973).
- (167) R. W. Richards, K. L. Perlman, and D. Perlman, *J. Antibiot.*, **26**, 177 (1973).
- (168) D. Perlman, S. Otani, K. L. Perlman, and J. E. Walker, *J. Antibiot.*, **26**, 289 (1973).
- (169) P. De Santis, *Jerusalem Symp. Quant. Chem. Biochem.*, **5**, 493 (1973).
- (170) B. Anastasi, F. Ascoli, P. Constantino, P. de Santis, R. Rizzo, and M. Savino, *Biochemistry*, **12**, 1834 (1973).
- (171) P. K. Ponnuswamy, R. F. McGuire, and H. A. Scheraga, *Int. J. Peptide Protein Res.*, **5**, 73 (1973).
- (172) H. Lackner, "Proceedings of the Third American Peptide Symposium," Ann Arbor, Mich., 1972, p 147.
- (173) U. Hollstein, E. Breitmaier, and G. Jung, *J. Amer. Chem. Soc.*, in press.
- (174) D. J. Patel, *Biochemistry*, **13**, 1476 (1974) (several other publications by Patel on this and related topics are forthcoming in *Biochemistry* and *Proceedings of the National Academy of Sciences of the United States of America*).
- (175) H. M. Sobell, *Jerusalem Symp. Quant. Chem. Biochem.*, **4**, 149 (1972).
- (176) P. Zipper, O. Kratky, H. Bunemann, and W. Müller, *FEBS (Fed. Eur. Biochem. Soc.) Lett.*, **25**, 123 (1972).